

Technical Papers

Development of Combined Automatic Blade Control for Snow-Removing Grader

Yukihisa Sakai

In snowy regions, improving the efficiency of snow-removing machines has been called for so as to reduce the time and cost involved in clearing the roads of snow. As a means of efficiency improvement, the operation of various large-sized machines for removing snow from four-line highways like main national roads has been automated.

For snow-removing motor graders (hereinafter referred to as snow-removing graders) too, a system for controlling the blade lift cylinder force at a constant value was put on the market in 1988. Since then, it has become widespread.

With the aim of raising the level of automation of the automatic blade control system for snow-removing grader and improving the efficiency of snow-removing work, Komatsu Ltd. carried out joint research and development with the Ministry of Construction (former ministry) and came up with a combined automatic blade control system for snow-removing grader.

This new system automatically controls the blade cutting angle, as well as the blade lift cylinder force. The term "combined" is used because the system controls both the blade lift cylinder and the power tilt cylinder.

Since this system leaves the judgment on the condition of snow removal from the road to the machine, the operator can concentrate his attention on his surroundings, hence perform the work more safely.

This paper describes the development of the combined automatic blade control system that began to be experimentally introduced in 2001.

Key words: Snow Removal, Motor Grader, Automatic Blade Control, Efficiency Improvement, Speed-up

1. Types of snow-removing machines

Snow-removing machines are generally divided into the following types:

- ① Plow type (e.g., the grader and wheel dozer) that pushes the snow on the road aside
- ② Rotary type that lets the snow fly off the road
- ① Other types (e.g., the chemical sprinkler) that use a non-physical method to maintain the desired road condition.

The plow type is further divided into various machines according to use. The device called a plow, which is fitted to the front end of the body of a truck, etc., pushes aside loose snow, such as new-fallen snow, at a comparatively high speed (30 km/h or more), hence it is used during the early stages of snowfall. The wheel dozer is capable of removing snow from parking lots, crossroads, etc. and stacking it elsewhere.

The grader has a blade at the center of its body and is capable of efficiently making the snow surface smooth. In addition, for a construction machine, it can travel at a high speed. Because of all this, the grader is most widely used in snow-removing work, which includes leveling snow and removing compacted snow.

Incidentally, the GH320 equipped with the combined automatic blade control system (**Photo 1**) has a body designed specially for removing snow. According to the established classification of snow-removing machines, the GH320 – a high-speed compacted snow-removing grader – is discriminated from the ordinary grader. Mechanically, however, it is the same as the ordinary grader, hence it is called a grader in this paper.



Photo 1 GH320 equipped with combined automatic blade control system

2. Difference from conventional automatic blade control

Having a high degree of freedom of motion, the grader can be operated with great versatility. On the other hand, since it has many levers to manipulate, operating it requires a high level of skill. For example, the right and left lift cylinders that push the blade against the ground work independently of each other. Therefore, without automatic blade control of the levers, it is necessary to manipulate them frequently. Because of this, automatic blade control has been applied to snow-removing graders (**Fig. 1**).

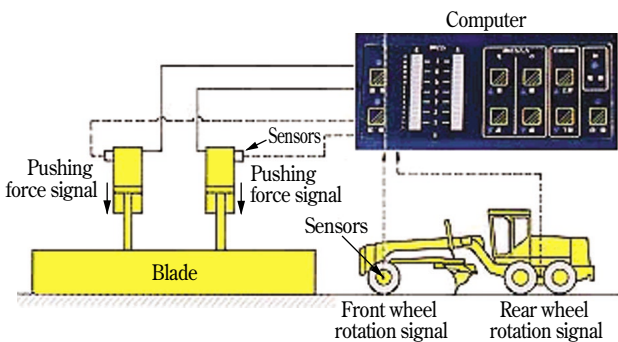

Fig. 1 Automatic control of blade pushing force

In the conventional automatic blade control, the lift cylinder hydraulic pressures are so controlled that the blade is pushed against the ground by a constant force. The operator is required to input from the operation panel a blade pushing force appropriate to the condition of the snow to be removed.

In the newly-developed combined automatic blade control, the blade pushing force is automatically controlled according to the condition of the snow to be removed, hence the operator

is not required to judge the condition. Needless to say, the facilitation of machine operation by automation benefits the operator. In addition, the improvement in work efficiency made possible by automation is expected to bring about a cost-cutting effect for the road administrators and a smoother traffic for the road users.

3. Outline of blade control system

The combined automatic blade control system is an attachment for snow-removing grader. It is offered as a higher option for the conventional automatic blade control. Therefore, in planning the system, the following two points were considered:

- ① The equipment shall be such that it can be installed to a GH320 that is already in operation.
- ② The program shall consist of routines which are made as simple as possible, and there shall be no need for complicated sensors.

Therefore, as the hydraulic circuit for controlling the blade pushing force, the standard one that is used in the conventional automatic blade control system for the GH320 was employed. Only solenoid valves and sensors for controlling the power tilt cylinder were newly provided. The system configuration is shown in **Fig. 2**.

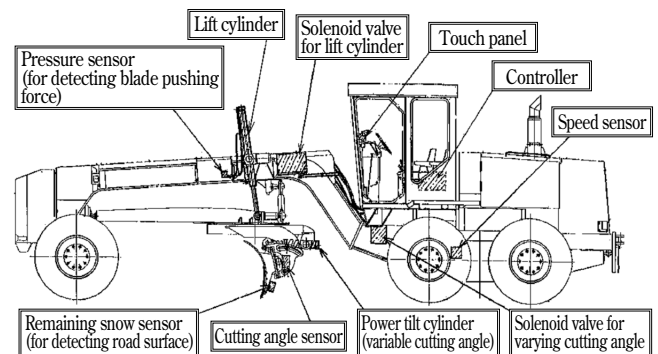

Fig. 2 Control system configuration

The touch panel for machine operation combines an input switch and a display. In view of the small volume of production of the new system, we adopted a general-purpose touch panel which is available on the market. Since the combined automatic blade control system employs an LX controller, it allows for RS-232 communications. This makes it possible for the system to use general-purpose devices, such as the one mentioned above.

Because of a surge voltage, etc., the conventional 24 V instrumentation for the body is unsuitable for the touch panel which is a precision device. Therefore, a power regulator is provided.

Since the touch panel permits freely setting the contents of screen displays and switches, more than 10 types of screens have been established. The initial setting for automatic blade control and the alteration of setting can be done by displaying the appropriate screens on the panel.

An example of screen display is given in Fig. 3, and screen transition is shown in Fig. 4.

The procedure of snow-removing work using the combined automatic blade control system is described below. Since the operator seldom needs to manipulate the levers, he can devote himself to the machine operation to remove the snow (Fig. 5).

- ① Start the engine, and the initial screen appears.
- ② Move to the road on which to remove the snow.
- ③ Push the SNOW-REMOVAL START button on the touch panel.
- ④ (The blade automatically descends to the ground. Now, move on the road. The blade pushing force and cutting angle vary automatically.) Use the appropriate levers to adjust the blade propulsion angle and lateral slide.
- ⑤ Push the STAND-BY switch at the point at which the work is completed. (The blade ascends automatically.) Push the STOP switch.

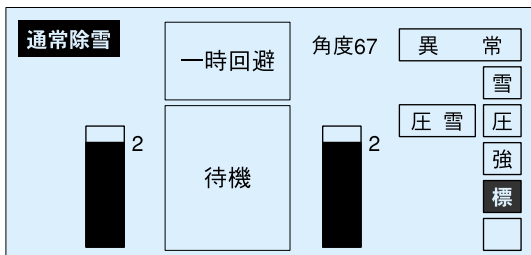

Fig. 3 Touch panel screen display during machine operation

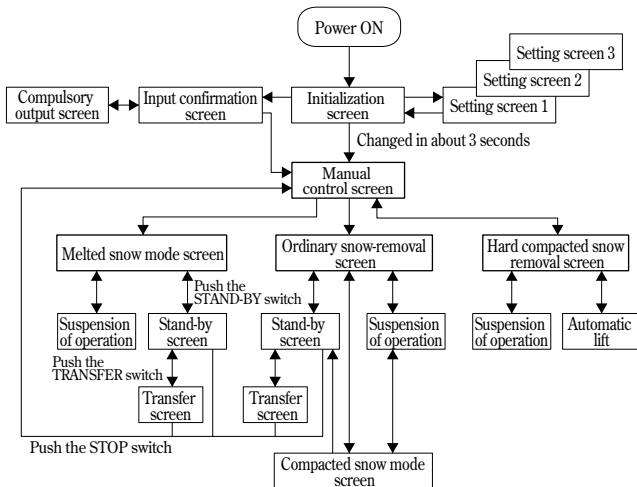

Fig. 4 Screen transition on touch panel

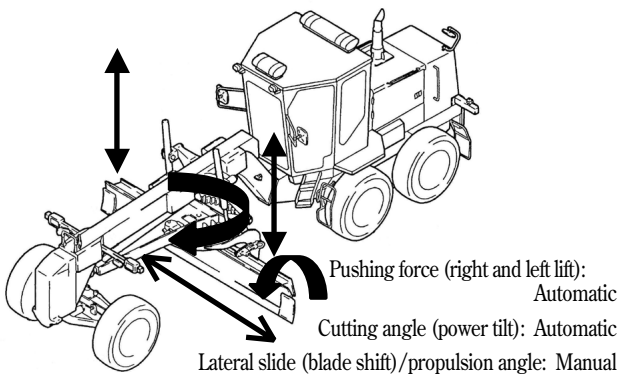

Fig. 5 Range of combined automatic blade control

4. Background to development

The development of combined automatic blade control was entrusted from the Ministry of Construction (former ministry). A fact-finding study on snow removal carried out in 1998 showed that the smaller the blade cutting angle (the blade tilted backward), the smaller is the snow-removing load and the better is the work efficiency. However, when the blade slides on compacted snow, it is impossible to let the blade cut into the snow merely by increasing the blade pushing force. In this case, therefore, the blade cutting angle is increased manually (see the effects of cutting angle in Fig. 6). The purpose of the development was to automate the control of the blade cutting angle and thereby bring the machine performance into full play.

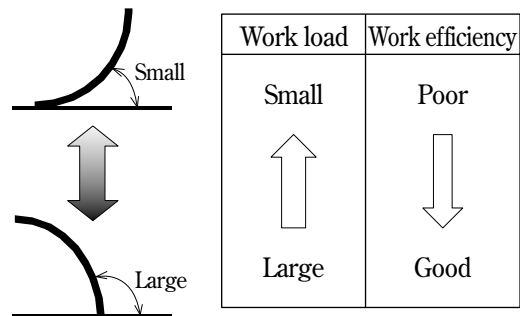

Fig. 6 Effects of blade cutting angle

We fabricated a prototype in 1999. Then, as described later, we confirmed the means of detecting the road surface and carried out field tests to determine the validity of combined automatic blade control.

In 2000, we made improvements on the prototype system and carried out tests for putting the system into practical use. With the aim of collecting data for comparison between the conventional control and the new control, the system was subjected to a field operation test throughout the winter of that year. On the basis of the test results, we made further improvements on the system.

The system was put on the market in the next year.

Since the testing could be done only during the winter of each year according to the contract, the development and design of the system had to be completed in a very short period of time.

5. Concept of combined automatic blade control

Improving the efficiency of snow-removing work entails increasing the speed of the snow-removing machine and decreasing the working hours. To do this, the following methods can be considered:

- ① Increase the engine output of the machine.
- ② Reduce the running resistance of the machine body.
- ③ Decrease the load of snow-removing work.

Items ① and ② are concepts that are already incorporated in the GH320 on which the new system is based. Therefore, Item ③ needs to be implemented. It should also produce some favorable effects, such as better fuel efficiency and less edge

wear, although substantial increase in machine speed cannot be hoped for. In addition, the planned automation should reduce the difference in work efficiency ascribable to the difference in skill between machine operators.

On the other hand, it has been known from the study results that when the cutting angle is large, the cutting edge can easily cut into the snow, but that when the machine is operated with the cutting angle kept fixed, the cutting edge wears easily, making the blade begin sliding on the snow surface too soon.

Under this condition, if the blade pushing angle is increased inadvertently, it can happen that the running resistance increases while the volume of snow removed remains the same.

In such a case, an experienced operator uses the power tilt mechanism to tilt the blade forward little by little till the corner of the cutting edge cuts into the snow. Conversely, where the snow is soft (not compacted), the operator tilts the blade backward to 'grind' the cutting edge (Fig. 7).

The new system is intended to automate the above operation and thereby improve the snow-removing capacity and work efficiency without relying on the blade pushing force.

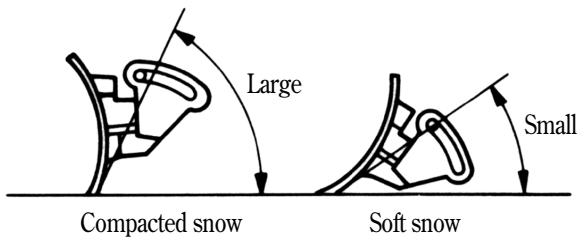

Fig. 7 Cutting angle

6. Iso-traction diagram

If the blade pushing force and cutting angle are independently controlled by using separate sensors, the control logic becomes complicated and the development period increases.

Therefore, we decided to prepare from the snow-removing load measurement data an iso-traction diagram which makes the machine traction constant with the blade cutting angle and pushing force as parameters and to set the pushing force and cutting angle in a fixed pattern according to the diagram. The iso-traction diagram is given in Fig. 8.

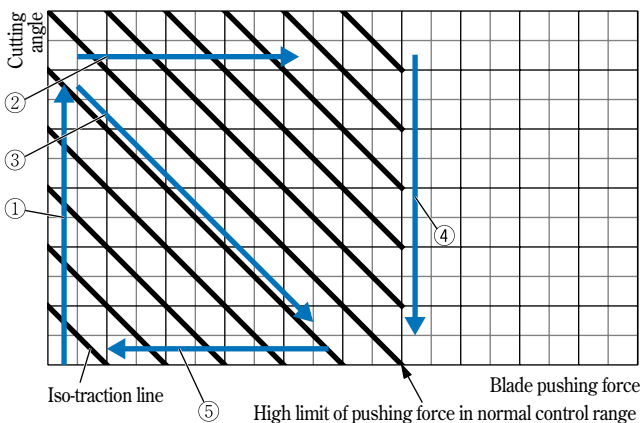

Fig. 8 Iso-traction diagram

Following are the two basic patterns of operation:

- Before increasing the pushing force, the cutting angle is increased to facilitate the cutting edge to cut into the snow.
- After that, the cutting angle is made to gradually return to its minimum so that it does not remain large.

As described below, the above operation is performed while the presence or absence of snow on the road is judged by a sensor described later.

- (1) When the blade leaves snow on the road
 - ① The cutting angle is increased.
 - ② If the snow still remains on the road even when the cutting angle is increased to 90°, the blade pushing force is increased.
- (2) When the blade exposes the pavement surface
 - ③ The cutting angle is decreased while the pushing force is increased along the appropriate iso-traction line.
 - ④ When the pushing force becomes its maximum, only the cutting angle is decreased.
 - ⑤ When the cutting angle becomes its minimum, the pushing force is decreased.
- (3) When the snow still remains on the road

Based on the pushing force and cutting angle at the time when the remaining snow is detected, the operation returns to ①.

As long as the road surface condition remains the same, the operation pattern after detection of the pavement surface is such that the cutting angle is gradually decreased while the pushing force is gradually increased according to the iso-traction diagram. In actual snow-removing work, however, the road surface condition is variable. Besides, there are various disturbances. Accordingly, the operation pattern is variable. In view of this, a kind of hysteresis has been given to the diagram so that the snow-removing capacity increases as the cutting angle is decreased.

In this control, the pushing force is decreased after the cutting angle is decreased once. It follows, therefore, that when the road surface condition remains nearly the same for some time, the operation pattern becomes a triangle on the iso-traction diagram, with the cutting angle being between the minimum of 60° and 65° and the pushing force being 250 kgf.

Thus, the pushing force and cutting angle are automatically controlled according to the condition of contact between the blade and the road surface. Therefore, the operator can concentrate on the machine operation for changing the width of snow removal, etc. without paying attention to the condition of contact between the blade and road surface or the condition of snowfall.

7. Means of detecting road surface

In order for the system to determine whether or not the blade leaves snow on the road, the vibration that is produced when the blade makes contact with the road surface is sensed by a piezoelectric vibration sensor (**Photo 2**).



Photo 2 Vibration sensor

If the blade has left snow on the road, the vibration of the blade is small because the blade edge slides on the snow.

When the pavement surface has been exposed, the blade vibrates violently because of small irregularities of the pavement surface.

By sensing this difference in vibration, the system determines how much snow remains on the road. The vibration sensor is schematically shown in **Fig. 9**.

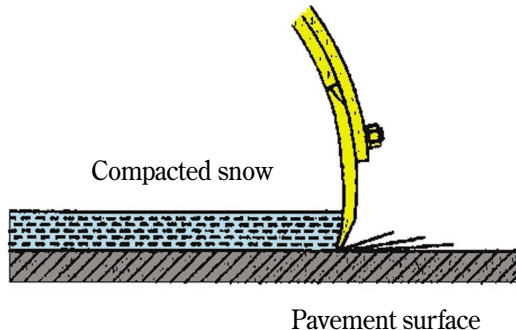

Fig. 9 Vibration sensor

The distinction between compacted snow and pavement is made based on the amount of vibration energy. The hardness of compacted snow to which the combined automatic blade control system is applicable is up to approximately 150 kg/cm². Compared with the hardness of pavement surface in winter, compacted snow is soft enough to allow for the distinction.

Harder compacted snow or ice (normally the hardness is about 200 kg/cm²) requires so much pushing force for removal that the front-wheel load of the snow-removing machine decreases. In such a case, it is necessary to perform manual work while moving the machine at a low speed. Therefore, it has been left out of the scope of automatic control.

When the blade angle and pushing force are being varied, the condition of contact between the blade and the road surface becomes unstable. Therefore, the detection of blade vibration

is done for several seconds after completion of the blade operation. Based on the result of detection, vibration detection is interrupted during operation of the blade (intermittent detection).

The key point of the combined automatic blade control is determining the presence or absence of snow on the road. In view of this, we considered several other methods, mainly optical ones, for detecting the road surface. Eventually, we adopted the present method because of its operational stability (it remains unaffected by bad weather) and low cost. The vibration sensor mentioned above varies in sensitivity according to direction (vertical and horizontal). Since the angle of the sensor against the road surface varies as the cutting angle is changed, we were not completely sure that the sensor would work. After carrying out a practical test, however, we found that the sensor could detect the blade vibration regardless of the cutting angle since the blade vibration contains both vertical and horizontal components.

8. Improvement of efficiency by additional functions

In the automatic blade control, it is possible to provide additional functions since the solenoid valves are actuated by the controller. For example, the automatic blade lift during backward movement of the machine has the following function.

When expanding the width of snow removal on a turn-left lane or bus stop, it may become necessary to perform a 'shuttle operation' which involves backward movement of the machine.

In order to eliminate the need to manually move the blade up and down during such work, while the automatic control is applied, the blade automatically moves up when the lever is shifted to REVERSE and automatically moves down to the ground when the lever is shifted to FORWARD.

Although this function was added as an 'extra' during the test, it was well received by operators. Therefore, it has been adopted as a standard feature.

In fact, in a single shuttle operation, the time required to change the levers can be reduced by several seconds. Considering that snow-removing work takes much time, several seconds may be insignificant. On the road, however, it often happens that the snow-removing work causes a traffic jam temporarily. In this context, curtailing even a short time is considered a benefit.

9. Verification of effects

We carried out an operation test on a snow station in the Hokuriku area throughout the winter of 2000.

In the test, one grader equipped with the combined automatic blade control system and one grader of the same type equipped with the conventional automatic blade control system (controlling only the blade pushing force) were used. The differences between operators and the data subject to the influences of machine deceleration required by other vehicles and traffic signals were omitted from the operation records.

As a result, it was found that the combined automatic blade control increased the average working speed by 7% as compared with the conventional automatic blade control. In manual operation not using the automatic control, an improvement of 18% was observed. The working speed frequency distribution for each grader is shown in **Fig. 10**.

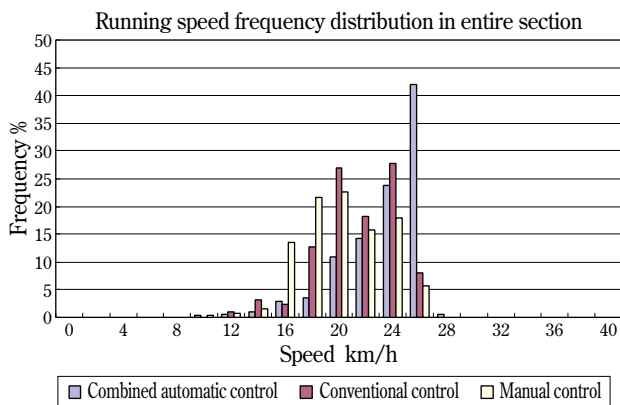

Fig. 10 Running speed frequency distribution

As shown in the figure, with the combined automatic blade control, the higher the machine speed, the greater becomes the frequency. This data was obtained at the maximum speed of fifth gear of a 7-speed manual transmission. If the test machine were equipped with an automatic transmission, the working speed could be further improved.

Except in the ascending section, the difference between the combined automatic blade control and conventional automatic blade control increased to 10%.

This means that the combined automatic blade control does not make much difference on upward slopes, whereas it makes marked difference elsewhere. According to the operators, in order to prevent the machine speed from declining on an upward slope due to an increase in running resistance, they sometimes intentionally decrease the blade pushing force and thereby reduce the machine load. Since the combined automatic control does not take the road gradient into account, it is considered that there is not much difference in snow-removing load between the combined automatic blade control and conventional automatic blade control.

10. Conclusion

The combined automatic blade control system was experimentally introduced in a new grader in the Hokuriku area in 2001. This year, it was also installed in a new grader delivered to the Tohoku area. The system is also sold as an attachment that can be installed in a grader in the field. At present, the system is only compatible with GH320 graders. In the future, we intend to make the system applicable to other models and develop an easier-to-use system.

Introduction of the writer



Yukihiisa Sakai

Entered Komatsu EST Corp. in 1995.
Currently working in Construction
Equipment Technical 2, Development
Division.

[A few words from the writer]

Although the snowfall has been decreasing year by year due to climate change, the snow-removing machines are ever increasing in importance as the road traffic has become sophisticated. We intend to make continuing efforts to make the Komatsu brand a mark of excellent reliability in the snow countries.