

Introduction of Products

Electronic Hydraulic System for PC950-11

Shinobu Nagura

Noritaka Nagata

The PC950-11, which was released in Japan in July 2022, is the full model change in 12 years from the conventional PC850-8E0, which is mainly used at stone crushing sites. To achieve both increased work volume and improved fuel efficiency, this machine introduced a new engine and a new hydraulic system including “Electronic Control Closed Loop Swing System”, achieving a 40% improvement in fuel efficiency. This paper describes the hydraulic system installed in the PC950-11.

Key Words: *Closed loop swing system, High-efficiency oil flow recycle system, Fuel efficiency improvement, Electronic hydraulic system*

1. Introduction

We are dedicated to our research and development, keeping in mind that the improvement of the fuel efficiency for the reduction of the total life cost of hydraulic excavators and achievement of carbon neutrality is important for enhancing the product appeal of our construction machines and is also our responsibility as a construction machinery manufacturer. Recently we have made efforts for carbon neutrality through electrification similar to the automobile industry, but this is limited to only a few models. In particular, cylinder drive systems using electric actuators such as electric motors are applied only to very small construction machines due to their power density, which is not only with Komatsu. While various options are considered as the power source, it is expected that hydraulic systems will continue to be used to drive actuators such as cylinders for the foreseeable future, so believe that it is extremely important to continue to improve the efficiency of hydraulic systems in order to improve the fuel consumption of construction machines.

2. Electronic hydraulic system adopted in PC950-11

Methods to improve the fuel efficiency of the hydraulic system of excavators include reducing pressure loss, reducing leakage, and recovering and reusing (regenerating) the energy generated during deceleration. In particular, among the conventional hydraulic excavators, the pressure loss called “flow dividing loss” and the loss generated when the upper structure with very large inertia is driven or braked are comparatively large. We aimed at significant reduction of these losses with the PC950-11 (**Fig. 1**). **Figure 2** shows the overview of the electronic hydraulic system. In the conventional system, oil from the two work equipment pumps are divided to all work equipment to drive them. On the other hand, in the PC950-11, an electronically controlled pump for closed loop swing circuit is provided in addition to the work equipment pumps. For arm IN and boom LOWER circuits in the control valve, the structure of the spools is changed to enable high-efficiency oil flow recycling system, which will be described later. For boom LOWER, a separate oil flow recycle valve has been newly developed to improve lowering speed. For the control of the oil flow recycle valve and the control valve, electronic control of the spool is used in necessary parts to improve the fuel efficiency and ease of combined operation. The section in the control valve used for swing in the conventional system is now used as an attachment (ATT) valve section, making the system capable of meeting a variety of user’s needs.



Fig. 1 The PC950-11

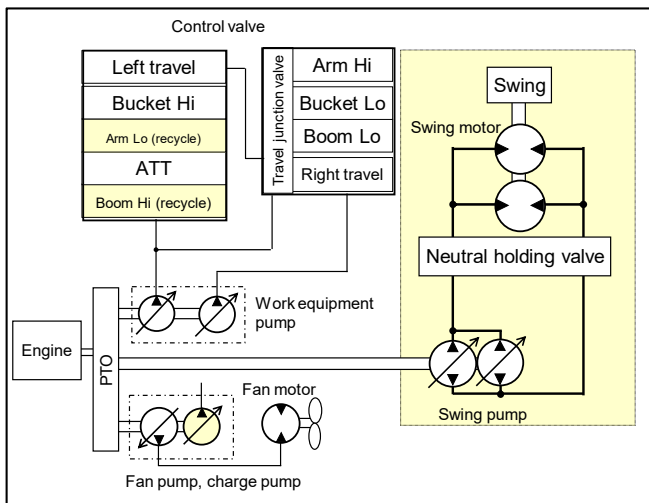

Fig. 2 Overview of the electronic hydraulic system of the PC950-11

3. Electronic control closed loop swing system

In the early days, the swing system of hydraulic excavators usually had an independent pump for swing operations to secure the operability for combined operations of swing and work equipment. Then, especially in medium-size excavators, the swing pump was abolished, and the 2-pump system with good QCD balance covering the work equipment and swing has become the mainstream until now. However, under the circumstances described above, improvement of fuel efficiency has become important. Many of the operations of the hydraulic excavator are combined operations with swing and work equipment, which causes flow dividing loss. Losses also occur due to acceleration and deceleration of the upper swing structure. So, we focused on a closed loop swing system that can reduce these hydraulic losses by separating swing and work equipment

circuits.

Komatsu has developed and installed closed loop HSTs (HydroStatic Transmissions) for the drive train such as bulldozers, wheel loaders, and forklift trucks. The closed loop swing system adopted for the PC950-11 utilizes this technology for swing drive of the excavator. It has the features shown in Fig. 3.

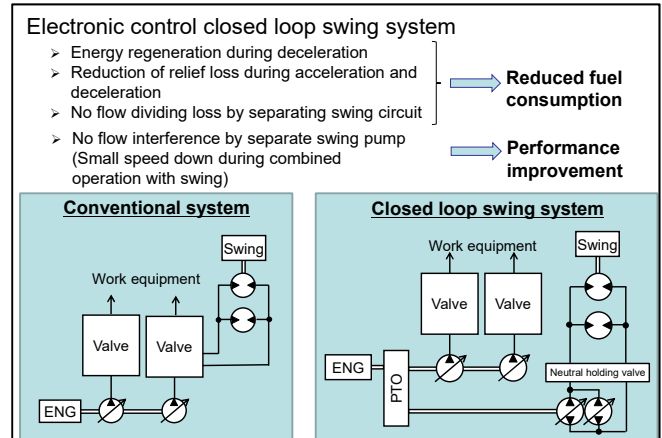

Fig. 3 Features of the closed loop swing system

3.1 Loss reduction by closed loop swing system

Here we describe the three items shown in Fig. 3 for the mechanism of the improvement of the fuel efficiency by the closed loop swing system.

3.1.1 Energy regeneration during swing deceleration

Figure 4 shows the energy flows during swing deceleration in the conventional system and in the closed loop swing system. In the conventional system, oil from the swing motor is throttled by the control notch in the swing spool in the control valve to build up a deceleration pressure to control during swing deceleration. In other words, the swing spool creates a loss (= deceleration pressure × return flow rate), and the kinetic energy of swing is released into the atmosphere. In the example of an automobile, this is the same as the disc brake generates friction heat to release the kinetic energy of the vehicle body into the atmosphere. This is a necessary loss in the conventional system.

On the other hand, in the closed loop swing system, the swing pump is driven by the oil released from the swing motor at deceleration and reversely drives the engine. This is equivalent to engine braking in an automobile. In actual work such as digging and loading onto a dump truck, the energy by the reverse drive of the swing pump

(regenerative energy) can cover a part of the energy consumed by the work equipment pump and fan pump, contributing to improved fuel efficiency. When the regenerative energy exceeds the consumption energy, the regenerative energy is wasted as this system does not have energy storage devices. However, in the main

operations of the hydraulic excavator such as digging and loading work, most of the operations are combined operations using more than one work equipment, so the energy wasted in actual operations should be small, although it depends on the operation.

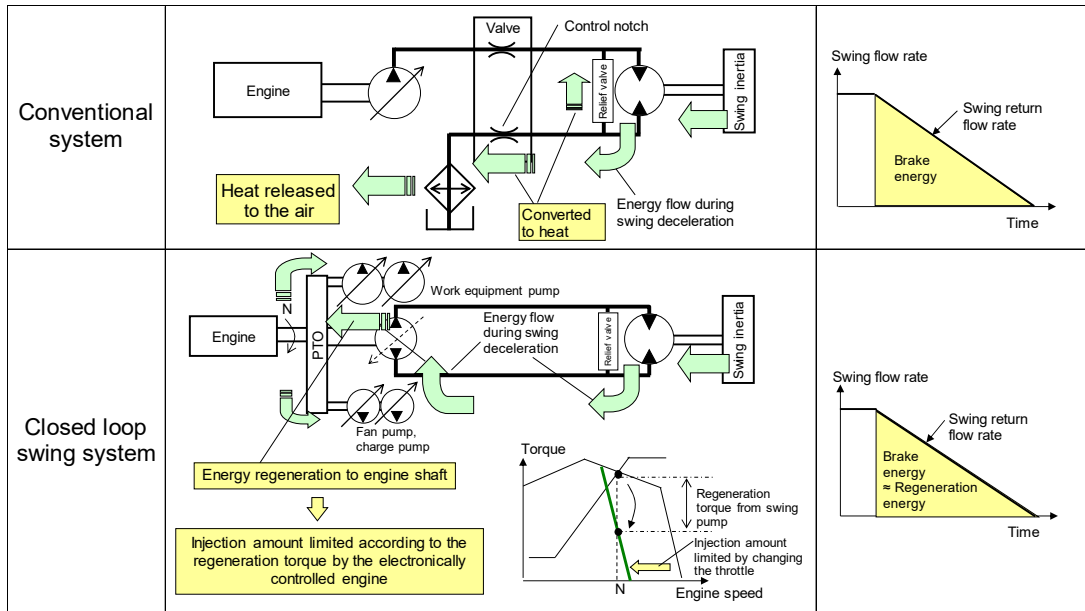

Fig. 4 Energy flow during swing deceleration

3.1.2 Reduction of relief loss during acceleration and deceleration

In the conventional swing system, most of the oil from the work equipment pump is dumped through the relief valve of the swing motor at the acceleration start from the swing stopped state. It is called relief loss. On the other hand, in the closed loop swing system, the pump flow rate is optimally controlled at acceleration and deceleration of the swing to minimize the relief loss (Fig. 5).

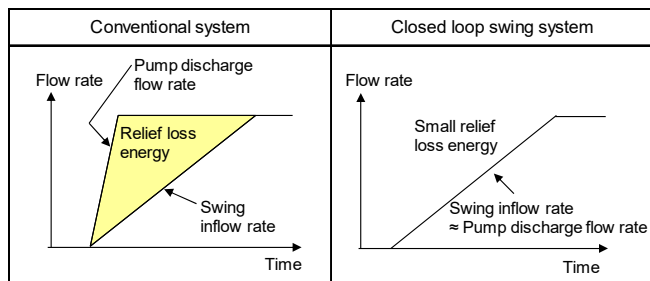

Fig. 5 Reduction of relief loss energy at acceleration

3.1.3 Reduction of flow dividing loss

Figure 6 shows the conceptual diagram of the flow dividing loss. To move more than one work equipment at the same time with a single pump, the control valve notch with the lighter load should be narrowed. This causes flow dividing loss. In the closed loop swing system, an independent circuit for swing is provided, so the flow dividing loss energy that occurs when swing and work equipment are operated simultaneously in the conventional system can be made zero.

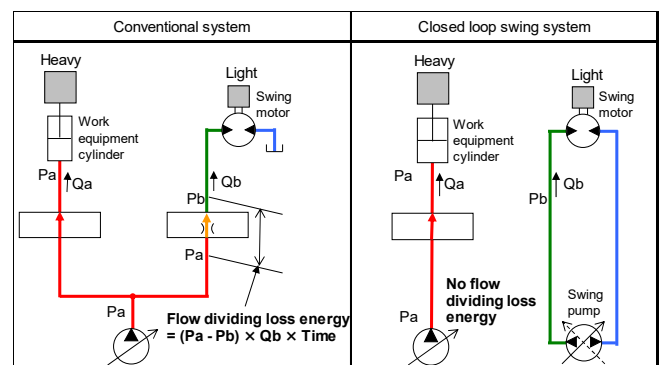

Fig. 6 Conceptual diagram of the flow dividing loss

3.2 Configuration of closed loop swing system for PC950-11

Figure 2 above shows the configuration of the electronic control closed loop swing system. In the closed loop swing system, a swing pump connected via PTO is provided separately from the work equipment (boom, arm, etc.) pump. The oil from the swing pump is delivered directly to the swing motor without going through the control valve, and the oil from the swing motor is directly drawn into the pump in the closed loop circuit. The pump is an electronically controlled pump whose displacement is controlled by the EPC (Electric Proportional Control) valve. The neutral holding valve is a valve to prevent hydraulic drift on a slope and uncontrolled falling at the start of a swing in the uphill direction. If the regenerative energy during swing deceleration exceeds the consumed energy and it is necessary to avoid an overrun in which the engine speed exceeds the allowable speed, the regenerative energy is converted into heat by narrowing the oil passage of the neutral holding valve. As mentioned above, such situations seldom occur in actual work, but this overrun prevention control is activated when the upper swing structure is simply decelerated to a stop in a swing-only operation. A variable displacement charge pump is installed to refill and replace the oil in the closed circuit of the system.

3.2.1 Swing control

To enable the improvement of the fuel efficiency described above and secure the operability better than that of the existing model in swing-only operation and combined operation of swing and work equipment, the closed loop swing system for the PC950-11 is electronically controlled. **Figure 7** shows the overview of the control items. For these control items, tuning has been conducted based on the control of the hybrid excavator HB205 in consideration of the difference in system response and machine size. The swing control systems for PC950-11 and HB205 are very similar, although they differ in whether they control the inverter controlling the electric motor or the displacement of the hydraulic pump controlling the hydraulic motor. There are many points in common, in particular, such as the method of generating swing speed commands and the tuning of combined operations of work equipment and swing. This enabled us to develop an electronic control closed loop swing system of high perfection. We developed the control software for the system efficiently by using MATLAB/Simulink ^{*1}.

*1: MATLAB/Simulink is a product of The MathWorks, Inc.

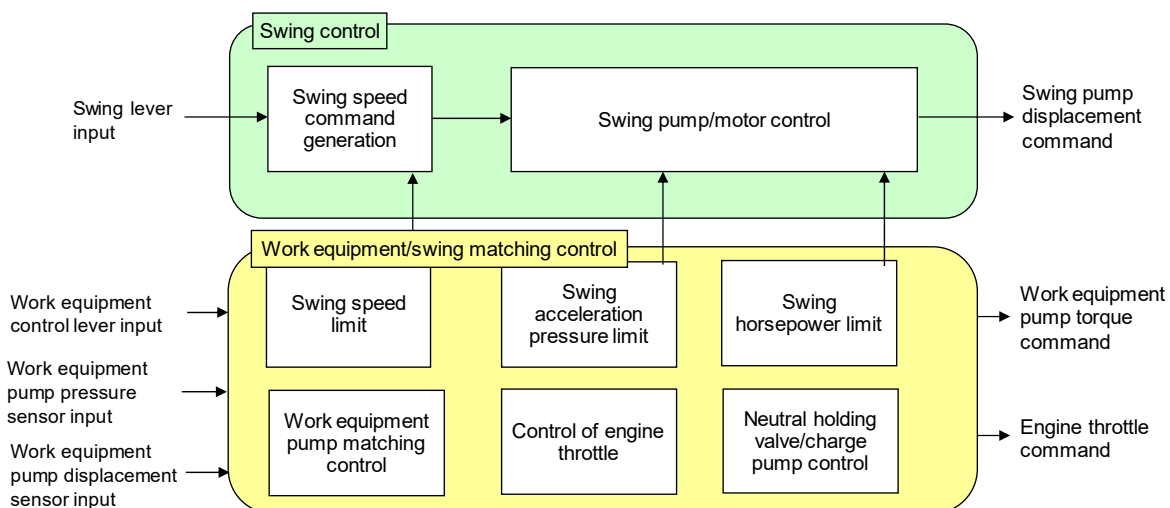

Fig. 7 Overview of the control of the closed loop swing system

3.2.2 Control of engine throttle

In the electronic control closed loop swing system, matching the absorption/regeneration horsepower of the work equipment pump and the swing pump and the engine output horsepower, as well as the operability, is very important for the improvement of fuel efficiency. To achieve

this, the engine throttle is controlled according to the regeneration horsepower of the swing pump, which changes from time to time. When a swing deceleration is expected from the operator's lever operations, the system predicts the torque regenerated from the swing pump to the engine shaft and instantaneously changes the throttle

command to lower the engine output torque while keeping the engine speed. By this control, the engine's fuel injection is efficiently controlled to enable the improvement of the fuel efficiency without wasting the energy during swing deceleration. The response of the engine's fuel injection improved from that of a decade ago by electronic control greatly contributed to it as well.

4. Work equipment electronic hydraulic control system

In the PC950-11, electronic control has been introduced to the hydraulic system not only for swing but also for the work equipment, greatly improving operability and loss reduction. Here is the description about it.

4.1 High-efficiency oil flow recycle system

Here we describe the high-efficiency oil flow recycle system, which is one of the measures for loss reduction with the work equipment. **Figure 8** shows the flow of the oil during a combined operation of arm IN and boom RAISE

with a light load. In the conventional system, one pump could not supply the flow used for arm IN, so oil from another pump for boom RAISE was added to the arm circuit. Since comparatively high pressure is required for boom RAISE, the oil had to be throttled before it was joined. This caused flow dividing loss. Therefore, the speed of the combined operation of arm IN and boom RAISE has to be limited. The PC950-11 is equipped with a high-efficiency oil flow recycle system for arm IN operations. In this system, some of the oil returning from the cylinder during arm IN is sent to the arm cylinder again for reuse, which reduces the flow rate of the oil to be sent from the pump. It was made possible to supply the flow rate for arm IN from a single pump. Then, the other pump can be fully used for boom RAISE, so that both the speeds of arm IN and boom RAISE are enhanced, contributing to the improvement in the work equipment speed and the fuel efficiency of the PC950-11. The high-efficiency oil flow recycle system is installed for boom LOWER as well, which contributes to the improvement of the work equipment speed when the load is light.

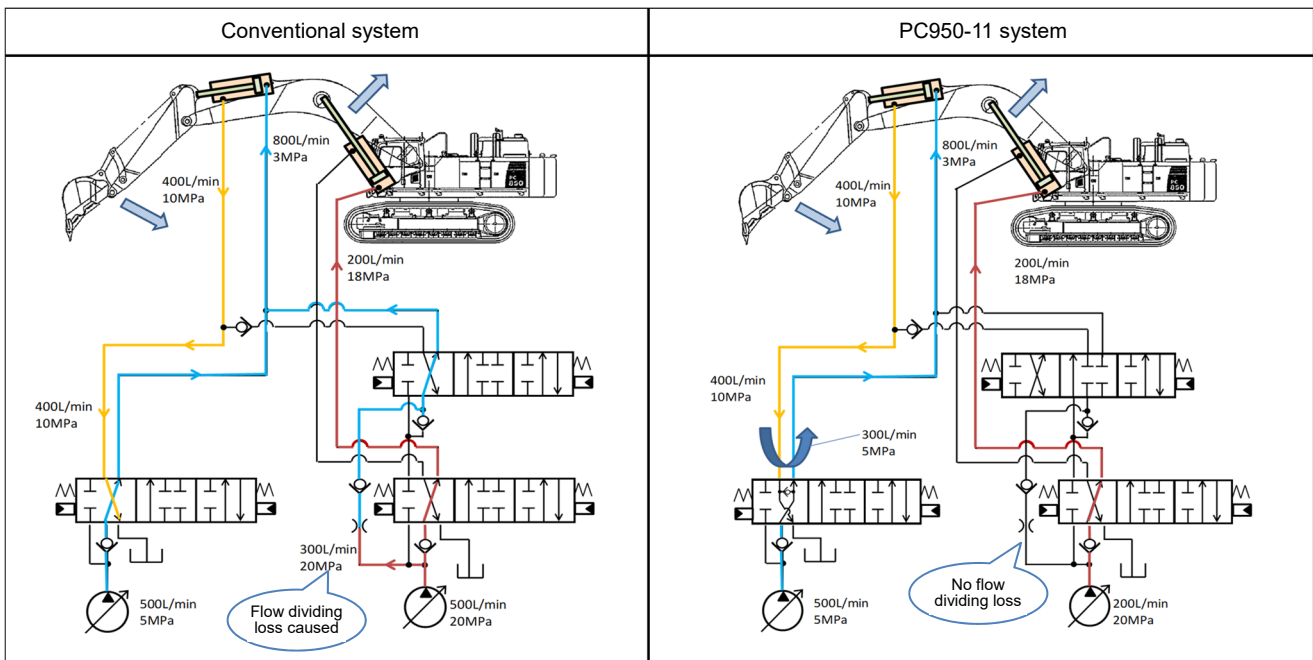

Fig. 8 Overview of the high-efficiency oil flow recycle system

4.2 Electronic control of control valve and pump

The control valve and the work equipment pumps are electronically controlled to reduce the working time with the improved operability and workability during digging and combined operation for the improvement of the fuel

efficiency. In the conventional OLSS (Open-center Load Sensing System), more oil flows to the work equipment with the lighter load during a combined operation, making the work equipment with the heavier load slower. In the PC950-11, the control valve and the work equipment pumps are electronically controlled to enable more oil to

flow to the work equipment with the heavier load side. **Figure 9** shows the flow of the oil from the pump during heavy-duty digging. In the conventional system, when trying to move the arm and the bucket against a high load in a soil digging operation, it will be basically a single-axis motion with the disadvantage of slow cycle time. To compensate for this disadvantage, the torque distribution of the pump, flow rate, and control valve are controlled. A system that can supply more oil to the arm, bucket, or boom according to the load has been realized to significantly improve the combined operability.

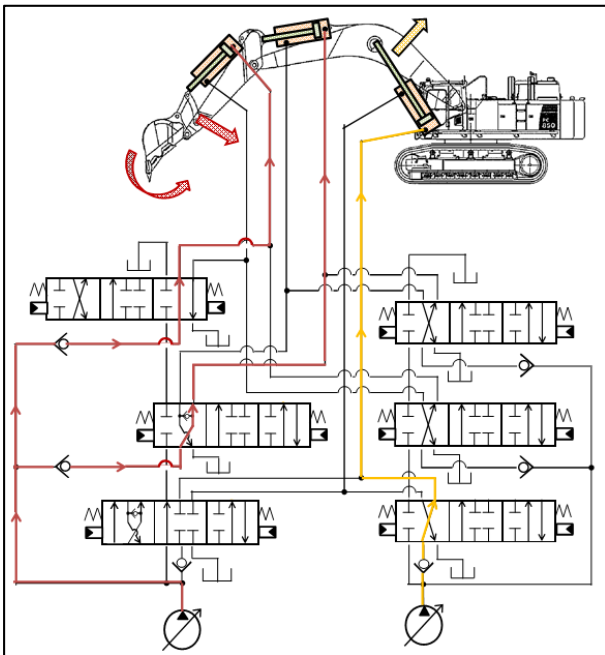

Fig. 9 Flow of the oil from the pump during heavy-duty digging

5. Light-operating effort PPC lever with hydraulic assist

The light-operating effort PPC (Proportional Pressure Control) lever with hydraulic assist has been newly developed and adopted for this machine as the interface between the operator and the hydraulic system, aiming at better operability and fatigue reduction for operators. Combined with the effects of the electronically controlled flow rate distribution, optimized horsepower distribution to the pumps, enhanced work equipment speed, closed loop swing system, and high-efficiency oil flow recycle system, the machine can now be operated very lightly.

6. Utilization of MBD and MBSE in development

MBD (Model Based Development) was adopted in the planning, research, and development of this system. Especially in the research stage, we made extensive use of simulations, mostly 1D-CAE, by inputting waveforms measured with the actual machine into the simulations to reproduce malfunctions. It enabled our high-speed development through the countermeasure examination, the effect confirmation, and the implementation of the control software. In the early stage of the research, we measured the waveforms in the actual machine tests in the daytime. We started simulations in the evening and held a meeting to decide on the countermeasure policy by the end of the day. The next morning, we created countermeasure software and confirmed its effectiveness through simulations, and then, confirmed the result with the actual machine at around noon. We repeated this cycle every day and have realized the fast development.

Before proceeding from the research to the development for mass production, we adopted the method of MBSE (Model Based Systems Engineering) to organize the vast amount of knowledge, including failures, obtained from the research and to visualize the process of reconstructing the knowledge to mass-production specifications. MBSE is a method to describe the specifications in a modeling language and it has the advantage of traceability of required specification changes and accompanying software design changes. This method was adopted later in the development of medium-size excavators as well.

7. Conclusion

The development of the hydraulic system of the PC950-11 started with the aim of significant improvement of fuel efficiency at the planning stage. Through the process for the installation to the actual machine, the improvement of the speed and the response of the work equipment, easy operation in the combined operation, the operability and workability including the digging power are confirmed as well as the fuel efficiency. We believe we have been able to commercialize the product in a way that takes advantage of these factors. The machine has achieved 40% enhanced fuel efficiency as a whole including the mounted new model engine. We expect that it receives high evaluation from the market.

Introduction of the authors



Shinobu Nagura

Joined Komatsu Ltd. in 1997.

Hydraulic Equipment Technical Center,
Development Division



Noritaka Nagata

Joined Komatsu Ltd. in 1995.

ICT System Development Center,
Development Division

[A comment from the authors]

The PC950-11 released in Japan in July 2022 is a model for which various people were engaged in research, development, and mass production with their enthusiasm. Along with our wishes, this model received an honorable reputation soon after its release. It is very delightful for us designers who had engaged in machine production from its planning. The launch into the overseas market is already announced. We hope the machine will be used by many customers and be appreciated for its advantages.