

## Technical paper

# Development of Super-large Control Valve

Daisuke Kozuka

*We have developed a new super-large control valve for the PC3400-11M0 mining excavator. In terms of in-house development, we went beyond just increasing the size of an existing valve, actively adopting new technologies such as an independent spool structure for neutral circuits and various in-house developed electronic equipment. Adopting these made possible optimal hydraulic control according to the situation of the machine. In addition, the use of many simulation technologies has reduced the amount of trial and error during quality checks, and shorten the development schedule.*

*This paper reports on this information.*

**Key Words:** Control valve, Super-large hydraulic excavator, ICT

## 1. Introduction

A control valve is an indispensable component for operating construction machines such as a hydraulic excavator as if they were an extension of the operator's body. There are diverse variations to satisfy the specifications and requirements of each machine, and we are one of the few construction machine suppliers that develop this control valve in-house. One of the advantages of in-house development is enabling more intricate design and tuning to meet the requirements of each machine, helping differentiate machine performance.

Now, we have marketed a new 300-ton class excavator, this paper introduces a super-large control valve developed in-house to replace the previously used control valve manufactured by other company.



**Fig. 1** Appearance of PC3400-11M0

## 2. Super-large control valve

### 2.1 Background

Among the series of control valves that we previously mass-produced, those used for 80-ton class hydraulic excavators were the largest. The rated flow is up to about 500 L/min per valve depending on the connected pipe size. The quantity of control valves is increased for models that require a higher flow rate, for example three control valves are used for the 125-ton class, and four control valves are used for the 200-ton class. In the same vein, a 300-ton class hydraulic excavator must be equipped with six control valves. This severely complicates the layout of the components and the routing of the piping mounted on the machine, with the risk of impairing the ease of assembly and maintainability.

On the other hand, the current mass-produced machine before the model change has three control valves manufactured by other company. It has already been in mass production for more than 20 years since its initial development, and there was an option to continue using it. However, this class of machine has a very long model change cycle compared to medium and small models, thus missing this model change would mean that the next change would not come for a while. Looking ahead 20 or 30 years into the future, we determined that it would not be possible to maintain competitiveness in the market with the valves used in current mass-produced machines, and decided to develop a new super-large control valve in-house.

## 2.2 Product series and features

### 2.2.1 Rated flow

In the course of development, the rated flow has been doubled from the 500 L/min of our previous product to 1,000 L/min, taking into account the future development of the series. However, applying this to the equivalent design from the previous products would result in the equipment itself being very large, hence from designing stage we made consultation with the manufacturing division to minimize the size increase. Although it is difficult to see once completed, the advantage of developing components in-house is also demonstrated in this regard.



Fig. 2 Appearance of the valve in this paper

### 2.2.2 Valve system

The control valve systems used in our hydraulic excavators are roughly divided into two types: Closed-center Load Sensing System (CLSS) and Open-center Load Sensing System (OLSS). Fig. 3 shows a comparison between CLSS and OLSS. The CLSS is capable of sending hydraulic oil to each actuator as intended by the operator irrespective of load by the effect of the pressure compensation valve in the control valve, and is characterized by excellent fine control performance and combined operability. On the other hand, the number of parts increases and the structure becomes complicated. Meanwhile, OLSS does not have a pressure compensation valve, so it is necessary to adjust the hydraulic pressure according to the machine situation to distribute the oil flow during combined operation, and the rest depends on the skill of the operator. However, it is characterized by a simple structure and superior maintainability to CLSS. In the course of development, we adopted OLSS to obtain strong reliability and durability.

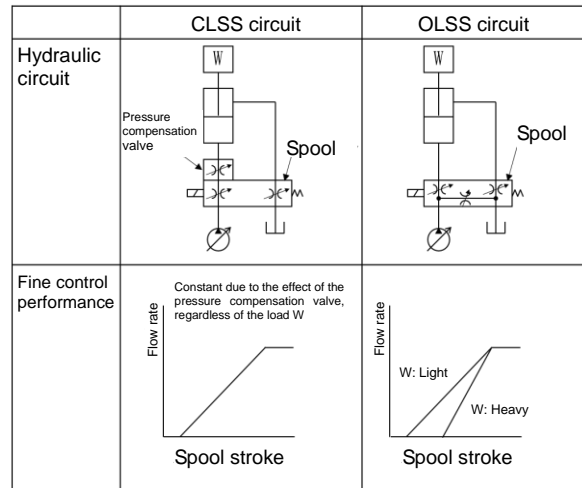

Fig. 3 Comparison between CLSS and OLSS

OLSS, as its name implies, has a neutral circuit called an open center from the pump to the tank on each spool. Therefore, the spool requires (1) a neutral circuit from the pump to the tank, (2) a meter-in circuit from the pump to the actuator, and (3) a meter-out circuit from the actuator to the tank. If this is laid out on each spool, the overall length of the spool will inevitably increase. Increasing the total length of the spool tends to increase the size of the valve body, which increases both the whole size and the weight. This raises the technical hurdles in various required aspects from machining to inspection and dimensional precision of the parts. In this valve, the neutral circuit from the pump to the tank has been made an independent spool. This structure helps to achieve both increasing the rated flow of the valve and reducing the overall length of the spool. In addition, there is potential for further benefits by making the neutral circuit an independent spool. Since the neutral circuit runs from the pump to the tank, the pump pressure can be freely controlled by its opening. By controlling the independent neutral circuit spool of this valve, the optimum pump pressure can be set according to the operating mode and load of the machine. This is one of the major features of this valve because it cannot be achieved with a conventional OLSS valve due to its structure.

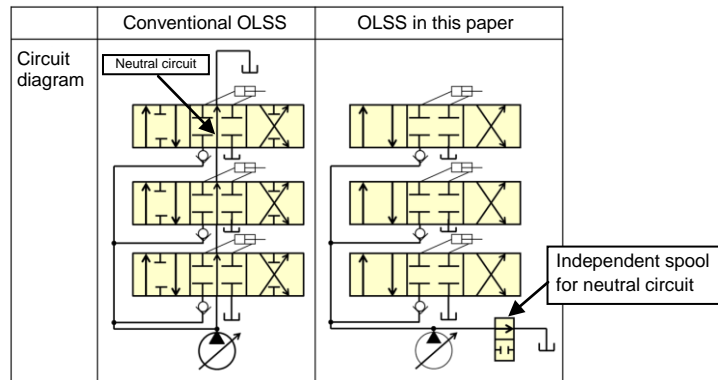

Fig. 4 Comparison between conventional OLSS and the OLSS in this paper

**2.2.3 Compatible with information and communication technology (ICT)**

The control valve distributes hydraulic oil sent from the pump to each actuator by switching an internal passage with parts called a spool moved by hydraulic pressure. Normally, the spool is driven by a hydraulic signal guided from a Pressure Proportional Control (PPC) valve installed in the cab to the control valve with a hose. The routing of hoses, especially in a large model with a large number of spools, becomes complicated because of the increased number of hoses for driving spools. Therefore, this valve adopted a system that drives the spool by an Electromagnetic Proportional Control (EPC) valve, and the EPC valves are mounted on the valve itself. This eliminates the need for hydraulic piping for driving the spool, simplifies the piping around the valve and improves maintainability. In addition, using EPC valves mounted on the valve eliminates hydraulic pressure loss in the hose, thereby the response of spool control is dramatically improved.

Furthermore for example, electrical control is applied to the signal to the EPC valve that controls the spool to reduce the shock to the machine body when operating the work equipment, and the spool itself functions as a pseudo pressure compensation valve during the aforementioned combined operation, enabling improved operability.

These are technologies that have already been marketed in our ICT-compatible models. In the valve from this paper, a spool stroke sensor was mounted on all spools so that the spool movement can be monitored in real time (Fig. 5). This allows the service technician to check the spool stroke on the monitor in the cab. The cause of trouble can easily and early be found in troubleshooting, and the machine’s down time be reduced.

As an aside, the EPC valve and stroke sensor (Figs. 6 and 7) are also in-house developed products. They are designed especially for use in the harsh environment of construction machine from the first.

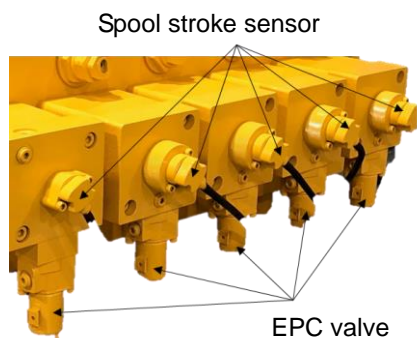

Fig. 5 Electronic equipment mounted on the valve

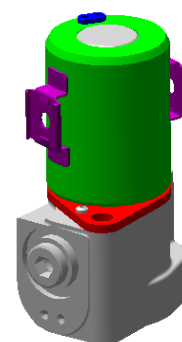

Fig. 6 EPC valve (in-house developed product)



Fig. 7 Spool stroke sensor (in-house developed product)

### 3. Quality confirmation

#### 3.1 Use of simulation technology

In normal development, several kinds of test parts are prepared, and each is mounted on a machine to check its performance. It is relatively easy to select the optimum part from among them. In some cases, it may be possible to reach the optimal solution more efficiently than an elaborate only one part tested by simulations. However, in the development of a super-large hydraulic excavator, each part is very big, so it takes much more time and cost from the production of a prototype to mounting it on the machine and checking quality, compared to conventional development. Therefore, in the

development of this valve, we used various simulations from the concept and design stages, and optimal parts obtained in the simulation were prepared for test. By reducing test parts as much as possible, we achieved the development cost reduction and shortening the schedule.

In particular, a new thermal strain simulation has been implemented in addition to the standard structural simulation and fluid simulation. Since it is the first application for hydraulic equipment, there is still room for improvement in the precision of analysis, but the simulation technology can potentially be further improved by increasing the analysis data in future development.

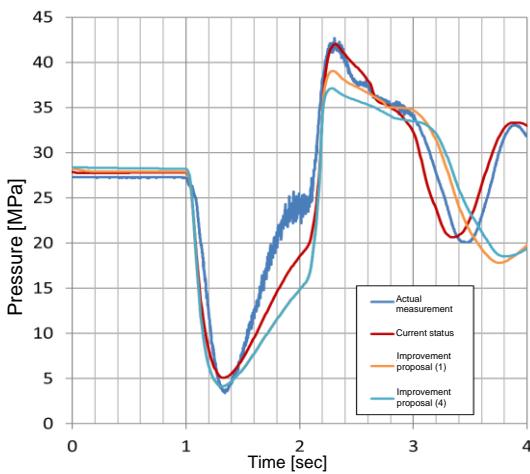

Fig. 8 Example of structural simulation

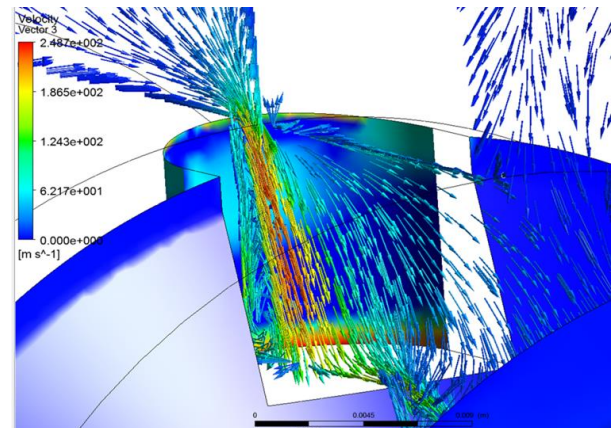

Fig. 9 Example of fluid simulation

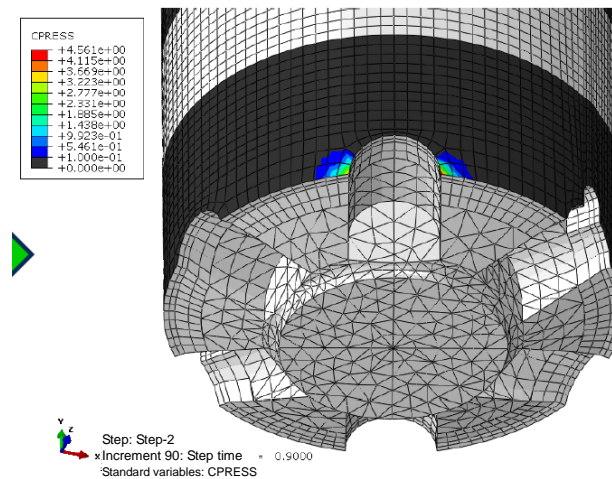

Fig. 10 Example of thermal strain simulation

## 4. Conclusion

The super-large control valve described in this paper is the first fully electrically controlled valve incorporating our various expertise from design to manufacturing. I am convinced that it has the potential to always meet the needs of state-of-the-art mining sites in the future.

### Introduction of the author



#### **Daisuke Kozuka**

Joined Komatsu Ltd. in 2002.  
Hydraulic Equipment Technical Center,  
Development Division

### [A comment from the author]

Development has been completed, but we still need to get the market's reaction. I am looking forward to seeing how our customers receive this control valve, which incorporates all of our expertise. I expect it to do good work at customers' worksite.