

Introduction of Products

Electrical Dump Truck 980E-4

Tom Wisely

Jeff Seiwel

Doug Surrat

Komatsu identified a product gap in the large truck market. We recognized a customer shift with the 360t (960E-2/2K) class moving to the 400 t class. In addition, we were offered a terrific opportunity for a large order in the Canadian oil sands region if we had a 400 t truck. In this report we would like to introduce the features of this new product

Key Words: Electrical Dump Truck, 400 t class, KomVision, high torque, gradeability, oil sands application

1. Introduction

The 960E-2 & 960E-2K have been successful products operating in the market since 2009. The market has changed since 2009 with a move to the 400 t class from 360 t class. Komatsu introduced the 980E-4 dump truck to compete in this class market. There were significant opportunities for sales in the Canadian oil sands for a 400 t truck starting in 2016. The design time was short if we wanted to compete in this opportunity. We used proven components to ensure that the 980E-4 would be successful and meet production timing. Komatsu has built a 400 t truck that successfully operates in several applications around the world.



Fig. 1 Side Views of 980E-4
(shown with customer specified dump body)

2 Aims of Development

While maintaining quality and reliability, develop a 400 t truck to meet the 2016 market demands. The 980E-4 had to have the latest in Komatsu ICT, including autonomous operation capability. The 980E-4 had to be able to operate in the tough, high torque, conditions of the Canadian oil sands, as well as other markets.

- (1) Production by 2016
 - 1) Short Development Schedule
- (2) Increased Productivity
 - 1) True 400 t payload
 - 2) 30% gradeability for oil sands operation
 - 3) Heated Dump Body
 - 4) New hydraulic cylinders
- (3) Improved Safety and Comfort
 - 1) KomVision
 - 2) Komatsu Retractable Ladder System (RLS)
 - 3) Ground Level Isolation Station
 - 4) LED Lighting
- (4) Adoption of Latest ICT
 - 1) Komtrax Plus
 - 2) Payload Meter (PLM) IV
 - 3) Komatsu Wireless Bridge (KWB)
 - 4) AT (Autonomous Truck) Ready
 - 5) MMS (Modular Mining System) Ready

3 Selling Points

This section describes the selling points of the 980E-4, and how they were achieved.

3.1 Increased Productivity

1) True 400 t payload

To achieve true 400 t payload, the 980E-4 was designed and tested considering the added weight of customer options. Many of these options were designed by Komatsu, so accurate weights could be accounted for.

Table 1 Shovel Match Chart

	Application	Actual Payload Per Pass (tons)		930E-4	960E-2	980E-4
				320st	360st	400st
KMC 4100 BOSS CAT 7495	Oil Sands	100	# passes	3	4	4
			Truck Load (ton)	300	400	400

The true 400 t payload allows the mine to operate a mixed fleet of trucks with one shovel size to achieve optimal loading and hauling.

2) 30% gradeability

Operating conditions in the Canadian oil sands become very difficult during spring because of spring thaw.

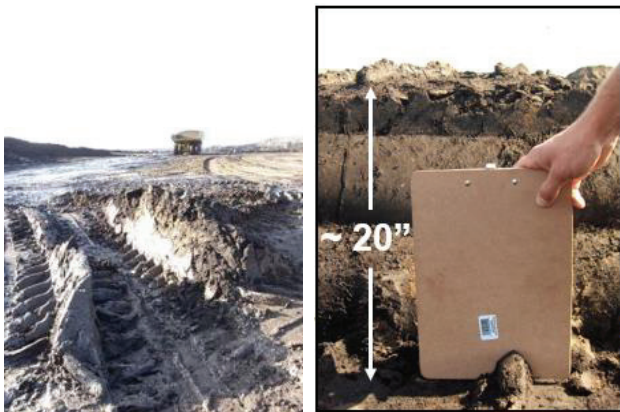

Fig. 2 Deep Tire Rutting

The picture shows deep tire rutting from spring thaw creating the need for high torque transmission to be able to pull through these soft conditions.

980E-4 has a new transmission with a 35:1 gear ratio helping the 980E-4 to achieve 30% gradeability. This is required to operate in soft underfoot conditions of the oil sands. The 980E-4 has the highest gradeability in the 400 t class.

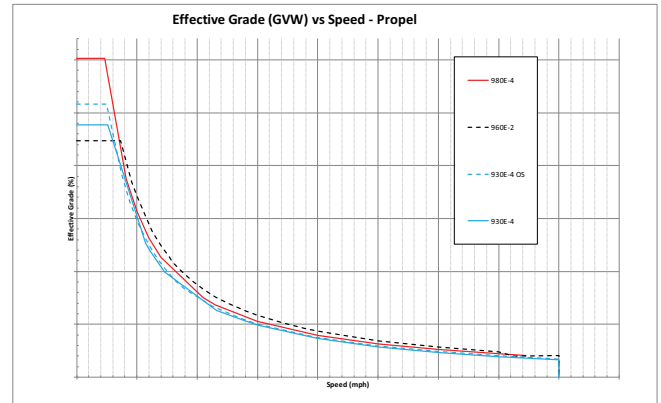

Fig. 3 Gradeability Chart

3) Heated Body

The oil sands ore is soft when extracted from the ground, and then freeze after it is loaded into the dump body. When it freezes it can stick to the body interior and not completely empty out when dumping.

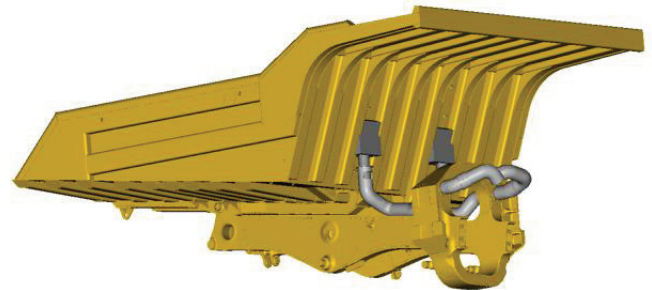

Fig. 4 Heated Body Exhaust

To overcome this issue the engine exhaust is routed through the dump body. The warm exhaust keeps the oil sand material from sticking to the body and during dumping allows the material to flow out. This is required for the very cold climate in northern Alberta Canada. The feature is used in several cold applications worldwide.

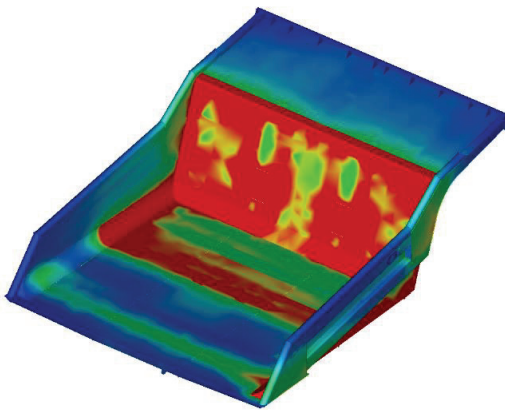

Fig. 5 Thermal Analysis of Heated Body

4) New Hydraulic Cylinders

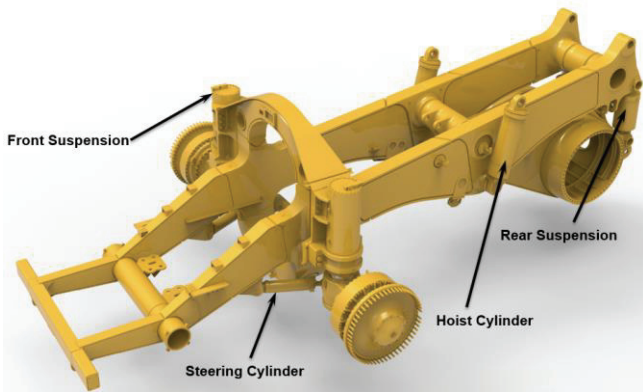

Fig. 6 Hydraulic Cylinders

980E-4 with 400 t payload required new suspensions which improved piston life, seal life, and bearing wear. The hoist cylinders and steering cylinders required a size change to match the requirements of the higher payload. We changed the design of these hydraulic components which allowed us to maintain current hydraulic system. This saved design time and cost.

3.2 Improved Safety and Comfort

1) KomVision

The 360 deg. all around monitoring system consists of cameras and radars. The display has a split screen. The LH side shows an overhead image of the machine periphery. The RH side can display whichever camera the operator chooses.



Fig. 7 KomVision Display Panel

If the radar detects an object, the RH screen will automatically switch to that camera so the object is displayed on screen. Also, when the shift selector is moved to reverse (R) the rear-view camera will be displayed on the RH screen.

2) Komatsu Retractable Ladder System (RLS)

The Optional Komatsu Retractable Ladder System was implemented to reduce risk of access/egress ladders being damaged during operation. Hydraulic pressure to operate the ladder is driven off the auxiliary hydraulic circuit. This eliminates the risk of bleeding off pressure from steering or brake systems with ladder operation. The system has logic incorporated that protects the ladder if the operator forgets to raise the ladder before starting to drive away. The ladder will automatically raise when the shift selector is moved out of the P (park) position.

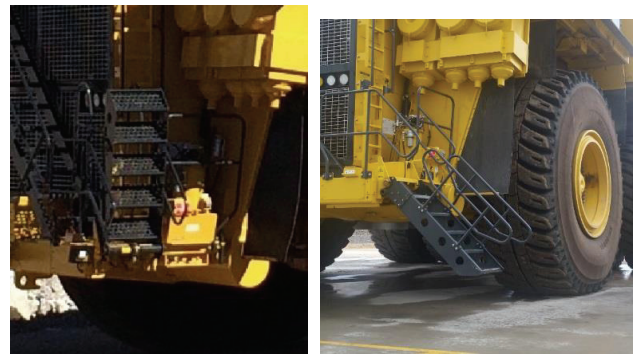

Fig. 8 Komatsu RLS in Up Position, Down Position

There is emergency release (ladder down) switches located at ground level, and along emergency egress path, to lower the ladder if the operator did not, or could not, use the in cab switch to lower the ladder.



Fig. 9 Secondary Egress Ladder

Komatsu RLS option also includes a manual fold-up ladder on the secondary egress side. This ladder is manually operated from either the ground level or the egress platform.

3) Ground Level Isolation Station

The truck is equipped with an isolation station at the ground level that allows service personnel to safely perform needed vehicle service. There are 3 methods of lock out available.

- a. Starter- Locks out only engine starters
- b. Master- 24V is off for the entire vehicle
- c. Propel- Locks out AC drive system-the truck will not propel (24 V still on).



Fig. 10 Isolation Station

Also located at this location is a ground level emergency engine shut down switch.

1) LED Lighting

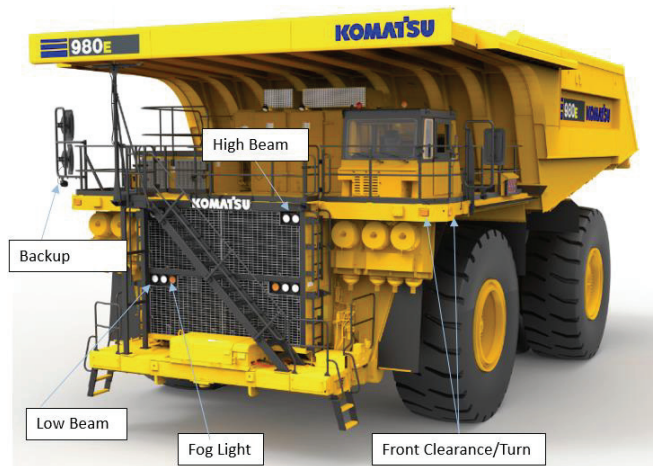

Fig. 11 LED Lighting Layout

980E-4 is introduced with LED lights on the truck. The LED lights have exponentially better life than halogen, and the quality of the LED emitted light is superior to the halogen. The LED headlights and backup lights provide better night visibility, and the LED clearance/turn lights provide better day and night recognition.

3.3 Adoption of Latest ICT

1) Payload Meter (PLM) IV

PLM IV is state-of-the-art weight measurement device used in Komatsu Electric Dump Truck (EDT) and is backward compatible with the previous generation PLM III. PLM IV has an internal inclinometer that is used along with suspension pressures, vehicle speed and other parameters to calculate the payload weight. This payload is shown to the operator on the digital dash display.



Fig. 12 Digital Dash Display

The information is relayed to shovel operator through either red/green/amber payload lights mounted on the vehicle deck, or the optional scoreboard display. This payload data and all relevant truck parameters are recorded for each haul cycle. Real time data is taken at 50 samples per second, and PLM IV has expanded haul cycle storage capacity to 18,432 records. This correlates to approximately 2 year’s worth of haul cycle data. The main interface is via Ethernet Port and is compatible with any web browser.

PLM IV also adds J1939 CAN 3rd party Bus interface. Software updates can be done in the field via USB flash drive.

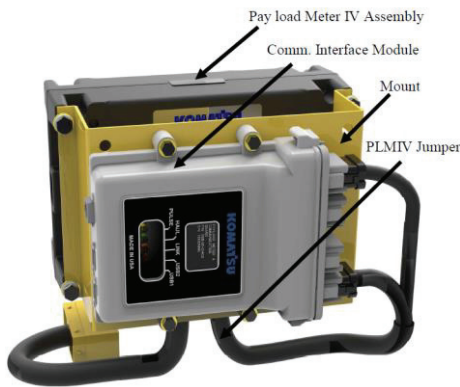

Fig. 13 PLM IV Assembly

2) Komatsu Wireless Bridge (KWB)

KWB is a system that uses commercially available wireless technology to allow communication that would normally require a wired connection and technician on board the truck. KWB Communication requires an access point and haul truck equipped with wireless communication devices. A laptop running the Komtrax Plus PC tools connected to the access point can automatically collect Komtrax Plus downloads when the truck comes in range. This can be setup in fueling areas so downloads can conveniently be collected automatically each time the truck/s stop for fuel.

3) MMS Ready

MMS ready makes it easy to add Modular Mining management products to the 980E-4. Electrical connections and mounting locations have been provided for faster installations. This is a competitive advantage over our competitors. Modular DISPATCH fleet management and Modular MineCare maintenance management are products widely used by open pit mining customers.

4) Autonomous Track(AT) Ready

During the design of the 980E-4, provisions were made to allow for easier retrofit conversion from a standard truck to an autonomous operation truck. Provisions were made for mounting of antennas and mode lights, and inclusion of necessary wiring into the standard truck harnesses.

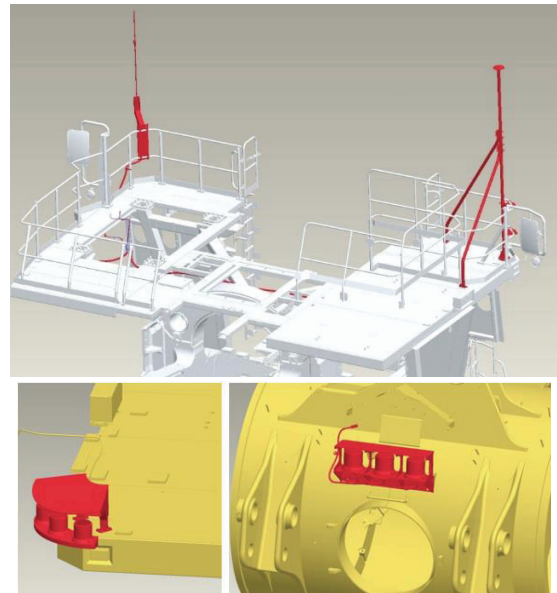

Fig. 14 AT Ready Provisions

Also, provisions were made in the Auxiliary cabinet (Electrical system hub of truck) to allow for mounting of AT components.

Introduction of the authors



Tom Wisely

Joined Komatsu America Corp. in 1995.
North American R & D
United States Technical Center 2



Jeff Seiwel

Joined Komatsu America Corp. in 1998.
North American R & D
United States Technical Center 2



Doug Surrat

Joined Komatsu America Corp. in 2014.
North American R & D
United States Technical Center 2

[A comment from the authors]

980E-4 had a very tight development window to meet the important opportunity in the market for this new truck. There was much collaboration required between engineering groups within USTC2, as well as NA R&D Test Group, to ensure we met our development schedule while still being diligent with our validation of the product. We would like to thank everyone for their efforts in making this development project a success.