

Introduction of Products

Hybrid Hydraulic Excavator HB335-3/HB365-3

Masaru Nakamura

Following products such as the 20t hybrid hydraulic excavators PC200-8E0/HB205-1/HB205-2 and the 30t hybrid hydraulic excavators HB335-1/HB365-1 for Australia and other overseas markets, Komatsu has been introducing 30t hybrid hydraulic excavators conforming to the Japanese Regulation of Emissions From Non-road Special Motor Vehicles (2014), the North American EPA Tier4 Final emissions regulations, and the European EU Stage 4 emissions regulations to the Japanese, American, and European markets since 2016.

In addition to our cultivated hybrid technologies, these 30t hybrid hydraulic excavators are featured with the latest fuel consumption reduction, safety, and ICT technologies to promote further evolution.

In this report we like to introduce the features of the new products.

Key Words: Hydraulic excavator, 30t class, Hybrid, Fuel consumption reduction, Low noise, Generator/motor, Swing electric motorization, Capacitor, Inverter, KomVision

1. Introduction

In recent years, in automobiles, hybrid vehicles and electric vehicles are being sold as a countermeasure to the problem of global warming. Also in construction machinery, we released the world's first hybrid hydraulic excavator PC200-8E0 as a commercial machine in 2008, changed the model to HB205-1/HB215LC-1 in 2010, released HB205-2/HB215LC-2 corresponding to the 2011 emissions regulations in 2013, introduced HB335-1/HB365-1 by expanding the series to 30t in the same year for overseas such as Australia, and thus worldwide sales exceeded 3900 units in total by the end of November 2016. Utilizing know-how and technology accumulated in these sales and market operations results, we developed the next 30t class hybrid hydraulic excavator HB335-3/HB365-3 (hereinafter referred to as HB335-3) and introduced it to the Japan, the United States, and European markets, and hereby introduce the outline (Fig. 1).

Because this machine conforms to the 2014 standards for emissions from non-road special motor vehicles, it is equipped with an exhaust gas aftertreatment device, which greatly reduces NOx and particulate matter (PM).

HB335-3 is geared to civil engineering work, and HB365-3 strengthens the work equipment and body for optimal use at the quarry.



Fig. 1 Appearance of HB335-3
(Quoted from catalog)

2. Aims of Development

Following the HB335/365-1 developed for strategic areas, we will develop a 30t hybrid machine that meets emissions regulations of Japan's next, North American EPA Tier4 Final, and European EU Stage 4, and will expand the market to the whole world. The outline and features are described below.

- (1) Environmental responses
 - 1) Applicable to the exhaust gas regulations of Japan's next, North American EPA Tier4 Final, and European EU Stage 4.
 - 2) Significant reduction in fuel consumption by hybrid technology
22% reduction vs. PC 300-10 (average working pattern comparison by KOMTRAX analysis)
 - 3) Compliance with JMLIT Ultra-low Noise Regulation (30t class, first in Japan)
- (2) Safety and comfort
 - 1) Improvement of machine circumstances visibility by mounting KomVision (circumstances monitoring system for general construction equipment)
 - 2) Pursuit for safety by automatic lock function of lock lever
- (3) ICT and relief

ICT technology has been further evolved and the following items have been added.

 - 1) High definition 7-inch LED monitor
 - 2) Acquisition of operator identification management information using an ID key
 - 3) Use of auto idle stop function
 - 4) Enhancement of KOMTRAX function

3. Selling Points

This section describes the selling points of HB335-3, and the means and techniques to achieve them.

3.1 Overview of Hybrid System

The hybrid system follows the conventional systems of HB205-1, HB205-2, and HB335-1 and consists of a self-developed electric swing motor, a generator/motor, an inverter, and a capacitor.

The kinetic energy of the upper structure at the time of the swing braking is converted into electric power and supplied (stored) to the capacitor. Since swing is performed fully electrically, there is no loss of hydraulic pressure and the whole amount of energy at deceleration can be recovered. In addition, the generator/motor uses this electric power to assist the engine at the time of acceleration, and generates power when the electric power of the capacitor decreases. The inverter controls this power frequently entering and leaving the capacitor.

One of the features of this hybrid system is the capacitor adopted to enable electric energy to be stored and discharged efficiently and instantaneously. (Fig. 2)

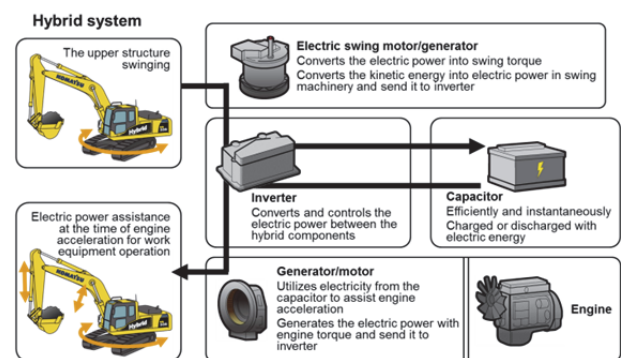

Fig. 2 Overview of Hybrid System

3.2 Components of Hybrid System

The hybrid components follow the components of HB335-1. Although some shape changes due to maintenance improvement are incorporated, the layout is the same as HB335-1, and it is loaded to the machine body of the PC 300-11 without changing the exterior dimensions of the body. (Fig. 3)

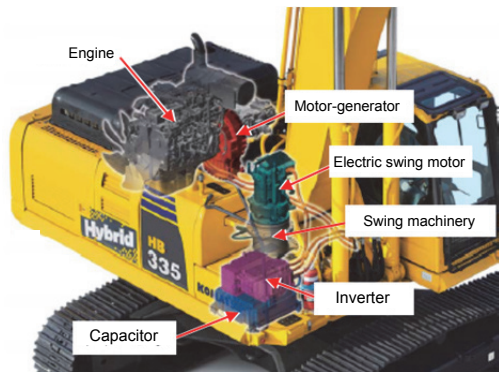

Fig. 3 Overview of Hybrid Component Installation

(1) Motor-generator

Since the generator/motor (Fig. 4) is built in between the engine and the hydraulic pump, it has high transmission efficiency, and realizes efficient power generation and excellent engine acceleration, aiming to reduce fuel consumption in the hybrid machine.

The generator/motor supplies power to the capacitor as a generator and supplies electric power to the electric swing motor at the time of accelerating the swing.

In addition, by making the generator/motor function as an engine acceleration assist motor, it is possible to maintain ultra low speed of the engine at the time of standby for operation and to keep ultra low speed idling so that the required rotation can be recovered instantaneously at the time of lever operation, thus adopting pump matching control with low engine speed with good engine fuel economy while securing necessary hydraulic discharge amount. HB335-3 improves engine and pump matching control and achieves further reduction in fuel consumption than HB335-1.

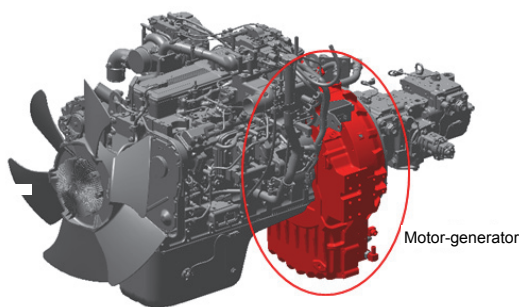

Fig. 4 Motor-generator

An SR (Switched Reluctance) motor is adopted as a generator/motor. The SR motor has a simple structure which does not use a rare earth magnet, and is excellent in heat resistance. This superior heat resistance improves the reliability of the built-in motor between the high temperature engine and the hydraulic pump. In addition, it does not use permanent magnets and therefore the dragging loss during idling while engine assist or power generation is not performed is extremely small, contributing to reduction in fuel consumption. However, the SR motor, due to the structure, has problems of vibration and noise, so there are few examples of practical application at high power. Table 1 shows the characteristics of the SR motor and the PM (permanent magnet) motor adopted for the electric swing motor.

Table 1 Features of SR and PM motors

	SR motor Switched Reluctance Motor	PM motor Permanent Magnet Motor
Example of use by Komatsu	Generator/motor	Electric swing motor
Driving force	Attraction force of magnetic coil	Magnetic force of permanent magnet and magnetic field of coil
Structure	Simple	Complicated
Permanent magnet	Not used	Used (rare earth magnet)
Heat resistance	High	Medium
Vibration and noise	Large	Small
Applications	Few	Many
	Oil pump, vacuum cleaner	Hybrid automobile, electric vehicle

The SR motor rotates as the rotor is attracted to the electromagnetic coil of the stator. As the electromagnetic coil is turned ON and OFF during rotation, attraction force is also repeated ON and OFF, causing vibration and noise. (Fig. 5)

The generator/motor for HB335-1 and HB335-3 has a higher output than HB205-1 by the amount of higher machine classification. Since the electromagnetic force is proportional to the output, the attracting force acting on the stator is larger than that of HB205-1, and it is necessary to increase the strength to the extent that the vibration and noise excitation force increases. Meanwhile, there are restrictions on the size of the motor that can be mounted on the machine, so the shape of the components such as the housing and the stator core and the drive control have been optimized by conducting FEA (finite element analysis) and various experiments and analyses. We have thus solved the problems of vibration and noise.

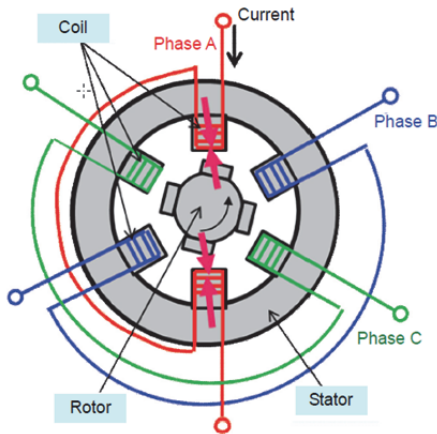

Fig. 5 Structure of SR motor

(2) Swing motor

Changing the hydraulic motor, which releases energy as heat during deceleration, to the electric motor enables energy to be recovered and stored in the capacitor. Reusing this energy at the time of driving has realized a significant reduction in fuel consumption. The electric motor also has the feature that it is more efficient in acceleration than the hydraulic motor and therefore can exhibit smooth turning performance. A reduction gear is added (add-on) to the swing reduction gear of the standard machine and the electric motor is used at high rotation to increase the efficiency of the motor and downsize it (Fig. 6).

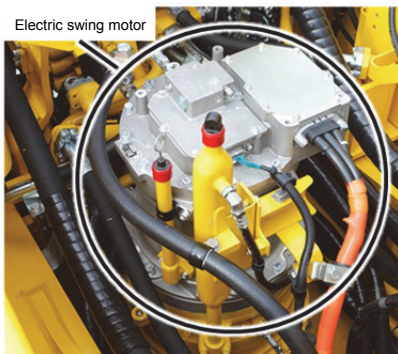

Fig. 6 Electric swing motor

(3) Inverter and capacitor

Minimizing the size increase of inverters and capacitors accompanying the output increase, which can thus be mounted in compact. They can be accessed with no tool and are easy to inspect. (Fig. 7)

The inverter is the component that converts/controls current and voltage between the capacitor, generator/motor, and electric swing motor. It enabled a great improvement of fuel consumption by allowing instantaneous efficient storage and output control according to the operating conditions of

the machine body that change frequently.

The capacitor is the component that stores and outputs surplus energy. Unlike ordinary batteries, it can charge and discharge only by movement of electrons and ions, and since it does not involve a chemical reaction, it enables charge and discharge in a short time. In addition, it is optimal for construction machines that continue to operate for a long period of time because of its slower degradation and longer life compared to batteries, and also because maintenance such as replenishment of battery fluid is unnecessary.

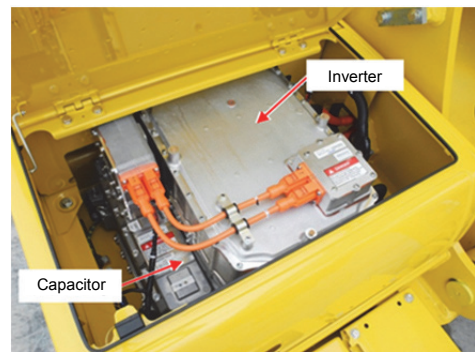

Fig. 7 Inverter and capacitor

3.3 Fuel consumption reduction effect

This machine achieves a significant reduction in fuel consumption while maintaining the same work performance as the standard machine by adopting the electronic control of the evolved engine, hydraulic pressure, hybrid system and the fan clutch system.

Compared with the standard machine PC300-10, an average 22% reduction in fuel consumption was achieved assuming that the work amount was the same. (Fig. 8) This is the result of actual measurement, by comparing both in average usage, based on the internal standard (the average operation pattern by analyzing the data acquired with the machine management system “KOMTRAX”).

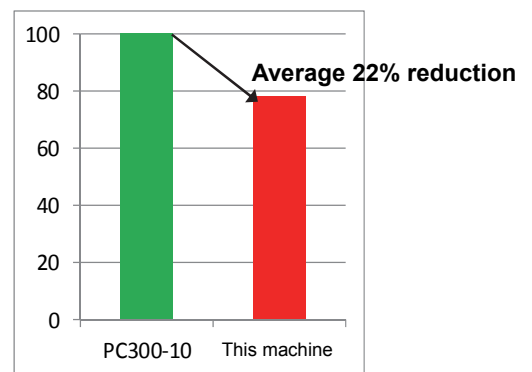

Fig. 8 Average fuel consumption

3.4 Noise Reduction

This machine has cleared the standard value of ultra low noise type construction machine for the first time in the industry in the 30t class. The noise of the ears of the operator is equivalent to that of the hydraulic excavator of the 20t class, and can operate in a comfortable environment. In order to realize super low noise with this machine, the following technologies are incorporated.

- (1) Reduced engine speed (slower than HB335-1)

In hybrid vehicles, engine rotation is controlled with respect to the load to reduce the rotation speed. This machine has further improved the control method to implement further reduction of rotation speeds from HB335-1.

- (2) Fan clutch installed

The fan is rotated at optimum speeds by sensing the engine coolant temperature and hydraulic oil temperature.

When oil temperature is low, fan rotation speeds are lowered to reduce noise and fuel consumption. (Fig. 9)

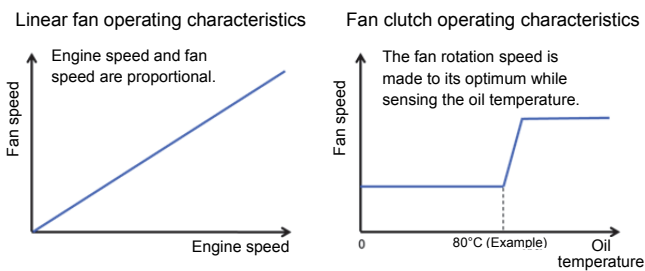

Fig. 9 Fan clutch control

3.5 Safety and comfort

- (1) KomVision (circumstances monitoring system for general construction equipment)

The periphery of the machine can be displayed as an overhead image on the monitor by using the four cameras installed on the sides and behind the machine (Fig. 10). (Fig. 11)

Standard equipment for Japan.

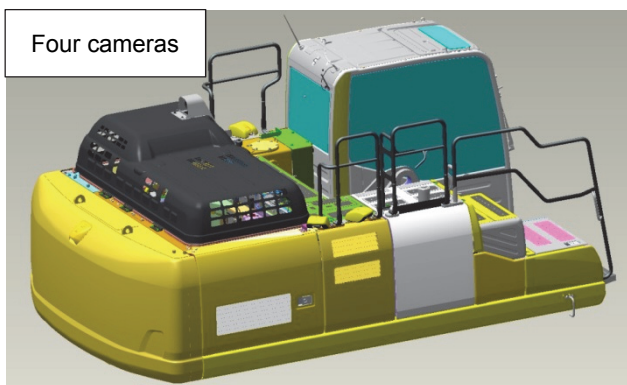

Fig. 10 Camera locations



Fig. 11 Monitor screen

- (2) Automatic lock function of lock lever

This machine is equipped with a system which, by shutting off the hydraulic source pressure, prevents the work or travel from starting even if the lock lever is released while operating the work equipment control lever or travel lever.

In that case, the automatic work equipment stop state is displayed on the monitor.

3.6 ICT and relief

- (1) High definition 7-inch LED monitor

This machine is equipped with a high definition monitor with a large screen. The monitor supports the display of various vehicle information, the reduction of fuel expenses using KOMTRAX, and the improvement of efficiency of vehicle management work.

It is designed to support energy saving operation and checking the load situation of the hybrid system.

- 1) Eco guidance, eco gauge, and fuel consumption meter

The monitor supports energy saving operation by displaying four types of ECO guidance in real time according to the driving situation, thereby informing the operator in a timely manner. In addition, the monitor has the function to display an eco-gauge and average fuel consumption. (Fig. 12)



Fig. 12 Eco guidance, eco gauge, and fuel consumption meter

- 2) Actual operation results, fuel consumption history, and ECO guidance record

From the ECO guidance menu, the user can display the “actual operation results window”, “fuel consumption history window”, and “ECO guidance record” to check the operation condition. (Fig. 13)

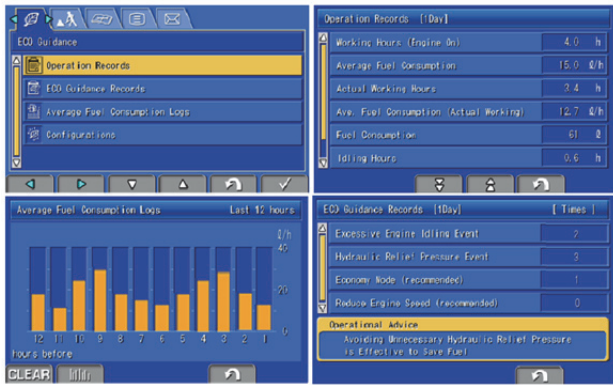

Fig. 13 Actual operation results, fuel consumption history, and ECO guidance record windows

- 3) Hybrid temperature gauge and energy monitor

The temperature gauge of the hybrid system is displayed on the monitor so that engine coolant temperature, hydraulic oil temperature, and hybrid system temperature can be checked at a glance.

In addition, the energy monitor window can be displayed by a single touch from the standard screen so the user can check the situations of capacitor charging/discharging and engine assist/generation of the generator/motor in an energy flow diagram. (Fig. 14)



Fig. 14 Hybrid temperature gauge and energy monitor

- (2) ID key (standard equipment)

An ID key with a built-in IC chip is a standard equipment as the ignition key. Engine starting is disabled with a key other than the registered ID key. Also, operator identification management information using an ID key can be acquired.

- (3) Auto idle stop

When the idling continues for a certain period of time, the engine automatically stops to prevent unnecessary consumption of fuel and generation of CO₂ and exhaust gas. The time to stop the engine can be adjusted.

- (4) Enhancement of KOMTRAX function

In addition to the conventional contents of the KOMTRAX report, information such as ECO guidance history, travel mode usage details, etc. has been added to enhance the contents. (Fig. 15)

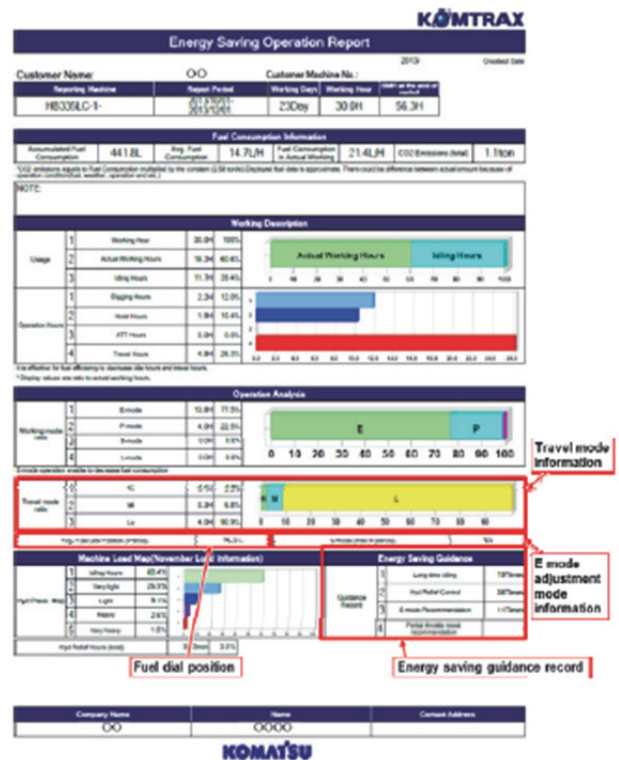

Fig. 15 Enhancement of KOMTRAX report contents

3.7 Other Features

- (1) Engine

In addition to improving technologies compliant with 2011 regulations, this machine contains the next generation engine which has drastically reduced NOx and particulate matter (PM) by adopting a new exhaust gas aftertreatment system that combines Komatsu Diesel Particulate Filter (KDPF) and Selective Catalytic Reduction (SCR). The engine has cleared the 2014 standards for emissions from non-road special motor vehicles.

It also realized a significant improvement in fuel consumption efficiency (fuel consumption map).

The engine output is the same as PC300-8 and PC300-10.

(2) Main pump

Main pump with a hydraulic pump mounted for lubrication of generator/motor and electric swing motor. The dedicated lubrication system using this lubricating oil pump secures the reliability of the generator/motor and the electric swing motor. (Fig. 16)

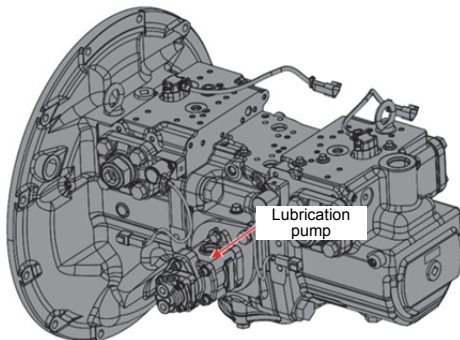

Fig. 16 Main pump

In addition, a swash plate angle sensor is attached to this main pump, and it is possible to lower the engine speed as much as possible after securing the necessary and sufficient pump discharge flow rate by sensing the pump displacement accurately. This has evolved the matching control adopted in HB205-1 and reduced fuel consumption by further reducing the engine speed.

(3) Enhancement of specifications

Attachments such as breakers, crushers, fork grabs were added to HB335-1, and further to HB335-3 two-attachment specifications, EU specifications, etc. have been added to make it the same lineup as the standard model.

(4) Working mode

Like HB205-1, -2, and HB335-1, the same variety of working modes as the standard machine can be selected and the E mode can be adjusted to enable the optimum operation suited to the situation of the worksite and the contents of work. (Fig. 17)

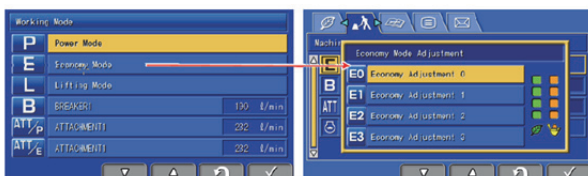

Fig. 17 Working mode selection screen and E mode adjustment screen

4. Conclusion

Following the introduction of the 20t hybrid hydraulic excavator in 2008, we have successfully mass-produced and market-introduced HB205-2 corresponding to the 2011 exhaust emission regulation and HB335-1 which is the expansion of the 30t series, followed by the 30t hybrid hydraulic excavator HB335-3 compliant with the 2014 regulations.

This machine conforms to the regulations of Japan, the United States and Europe, and furthermore it has successfully evolved the conventional hybrid technology to further improve fuel consumption and quietness. We would like to expand the market of hybrid hydraulic excavators to the whole world with this machine.

Introduction of the writers



Masaru Nakamura

Joined Komatsu Ltd. in 1989.
Environment Specification Product
Development Group, Construction
Machinery Development Center 1,
Development Division

[A few words from writers]

With the cooperation of many stakeholders, we have successfully made up this machine to be competitive and attractive as a result of reducing emissions, reducing fuel consumption, improving quietness, improving safety, and incorporating the latest ICT technology.

We would expect that in the future the machine earn high customer reputation around the world.