

Introduction of Product

Introduction of Wheel Dozer Model WD600-6

Keiichi Mokka

Kaichi Endo

A new Wheel Dozer Model WD600-6 fully meeting the Tier 3 emission regulation has been developed as a model change version of the Wheel Dozer Model WD600-3. The features of the new wheel dozer are described.

Key Words: *WD600-6, Wheel dozer, Tier 3 emission regulation, Electric mono lever with electric detente, Low fuel consumption, Low noise*

1. Introduction

Since its sales launch in 2001, the WD600-3, which is a conventional model, has been in operation in mines worldwide and has earned a high user reputation.

The number of this wheel dozer model sold in the market is increasing each year, and since it meets the Tier 3 emission regulation, it is particularly in demand in regions where the EPA emission regulation is enforced.

The wheel dozer WD600-6 (**Photo 1**) meeting the Tier 3 emission regulation was developed and put on the market in 2009. Its features and technologies are outlined.



Photo 1 Appearance of WD600

2. Development aims

Based on the wheel loader WA600-6, which complies with the Tier 3 emission regulation, as a base model, the new WD600-6 wheel dozer inherits the excellent features and performance and basic concepts of its predecessor, namely, “Environment, Economy, Safety and IT.” The new model also incorporates new wheel dozer technologies as follows:

- ① Installation of the ecot3 (ecology & economy - technology3) SAA6D170E-5 engine as a means of meeting the Tier 3 emission regulation.
- ② The use of an electric mono lever with an electric detente unique to Komatsu to enhance operability.
- ③ The use of a new control mechanism for tilt and pitch cylinders on the left and right of the blade to enhance operability.
- ④ The use of a large-capacity torque converter, variable displacement piston pump and CLSS (closed circuit load sensing system) to reduce fuel consumption.
- ⑤ Enhanced comfortability through the use of a common cab, like that used in the WA600-6 wheel loader.

3. Principal Features

The principal features incorporated in the WD600-6 are described in the following:

3.1 Environmental Friendliness

(1) Compliance with the Tier 3 emission regulation

The ecot3 engine, Komatsu’s cutting-edge technology, is installed to meet the Tier 3 emission regulation without any decline in fuel consumption performance. The principal changes are as follows:

- The fuel injection system has been changed from the previous high pressure injection (HPI) system to a common rail system via electronically-controlled high pressure fuel injection, enabling fuel injection with a higher degree of freedom.
- The cooled exhaust gas recirculation (EGR) system is installed and the combustion temperature lowered to reduce NOx generation.
- The calculation results of combustion simulation are fully utilized and the shape of a combustion chamber changed to an unprecedented special shape. Emissions have been reduced and fuel consumption lowered by optimizing the combination with electronically-controlled fuel injection.

3.2 Enhanced Operability

(1) Use of an electric mono lever with electric détente

(Photo 2)

Wheel dozers are mainly used in collecting and rolling rocks and stones and when work is performed with the blade in the “floating” position (the blade moves freely while depending on an external force for operation in accordance with the road surface), a mono lever with a detente has been indispensable. By using the newly developed electric mono lever with an electric detente, the control force and stroke could be reduced by 50 and 15% respectively, thereby mitigating fatigue in work extending over many hours.



Photo 2 Electric mono lever with electric détente

(2) New control of tilt and pitch cylinders

Work equipment comprises a lift cylinder that raises and lowers the blade and left and right pitch cylinders that tilt (to the left or right) or pitch (forward or backward) the blade. (Fig. 1) Conventional models tilt (only the left cylinder is stretched or retracted) and pitch (left and right cylinders are stretched or retracted) by combining a control valve (one spool) and a flow concentration and dividing valve.

The following new controls are incorporated in the WD600-6 to eliminate the flow concentration and dividing valve, improve operability, reduce the number of parts and enhance maintainability:

- ① The number of spools in the control valve is increased to two, to control the left and right cylinders independently.
- ② A pressure compensating valve is added to each port to eliminate speed dispersions caused by load pressure in the left and right cylinders during pitch operation. (Fig. 2)

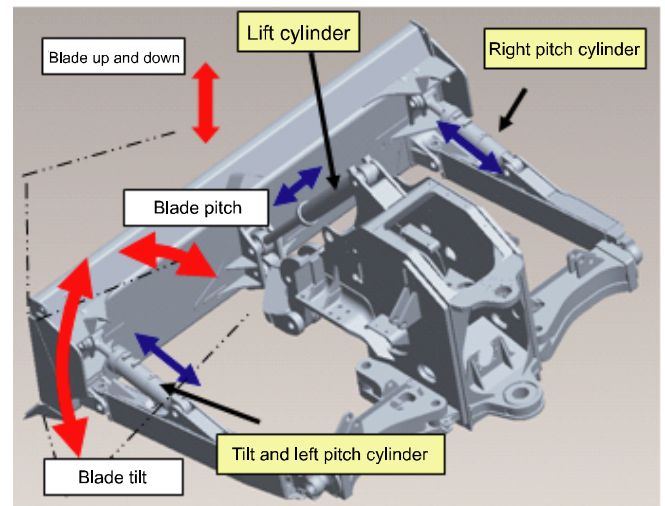

Fig. 1 Operations of the tilt and pitch cylinders

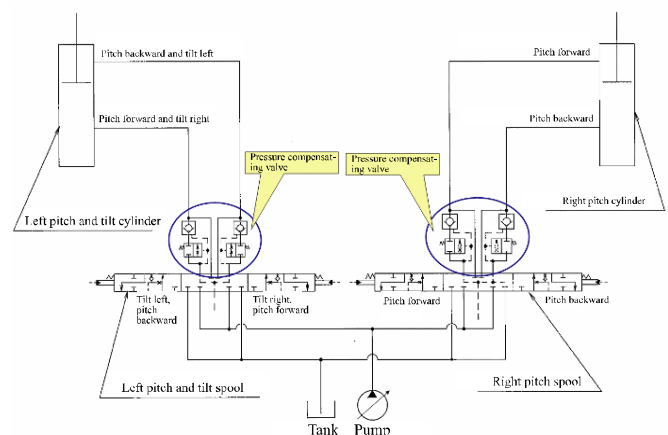

Fig. 2 Tilt and pitch cylinder hydraulic circuits

③To absorb dispersions in the flow dividing performance of the flow from the control valve to the left and right pitch cylinders, the speed of the left pitch cylinder during stretching and retracting is made adjustable. A new control mechanism to synchronize to the right pitch cylinder is used.

(3) Automatic transmission of the electronic modulation type for all gear shifts

An automatic transmission of the electronic modulation type for all gear shifts is employed to reduce fatigue during dozer operation over many hours by reducing shocks and time lags linked to frequent forward and backward traveling and gear shift changes. A learning control function is also provided to maintain the repletion time of the clutch piston chamber in order to prevent elapse change of the modulation characteristic due to wear on the clutch disc and other causes.

(4) Advanced Joystick Steering System (AJSS)

Compared with the conventional speed control type electric joystick, the AJSS is of the position control type as in the steering wheel type and enables worry-free dozer operation. (Fig. 3)

The system is used in super large loaders from the model WA600 upward and has earned a good reputation by significantly contributing to a reduction in work fatigue over many hours. (Photo 3)

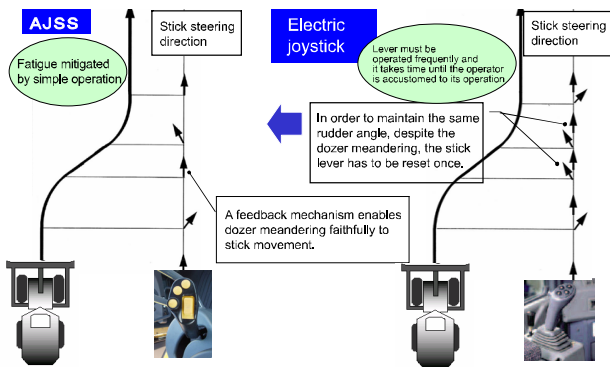

Fig. 3 Comparison between AJSS and electric joystick



Photo 3 AJSS lever

3.3 Environmental Friendliness

(1) Low fuel consumption

The following measures are incorporated as a means of reducing fuel consumption:

①The high fuel efficiency area of the engine is made usable by matching an engine of low revolutions and high torque and a large-capacity torque converter. Thanks to the use of a large-capacity torque converter, the absorption torque increases even when the engine is rotating at low velocity. Moreover, extra pressure on the accelerator pedal during startup and operation of the dozer is reduced, thereby reducing fuel consumption.

②Hydrau MIND System

The newly developed Hydrau MIND System (variable displacement piston pump + closed circuit load sensing system (CLSS)) is incorporated in work equipment and steering circuits, enabling a significant reduction in hydraulic losses compared with the conventional fixed displacement pump type. A relief cut function is also provided to control work equipment, thereby achieving a further load reduction. (Fig. 4)

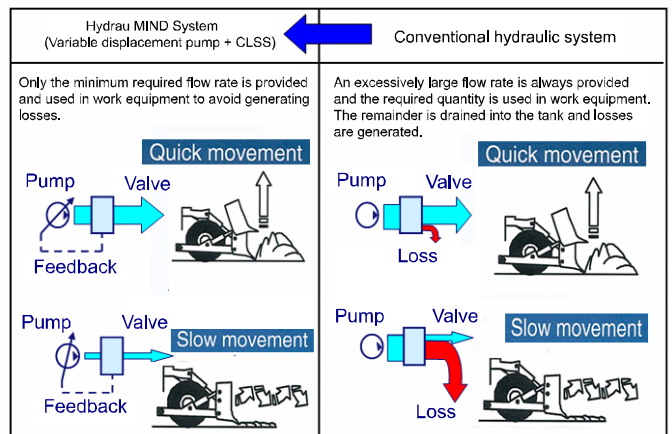

Fig. 4 Comparison of Hydrau MIND and conventional hydraulic system

③Dual-mode power select system

A system that can select engine output from two modes (P and E) is employed. (Fig. 5)

The mode select switch is of the momentary type and is set to select Mode E by default when the engine is restarted. The switch is set so that Mode P is selected as necessary such as when traveling on an upslope or dozing with a heavy load.

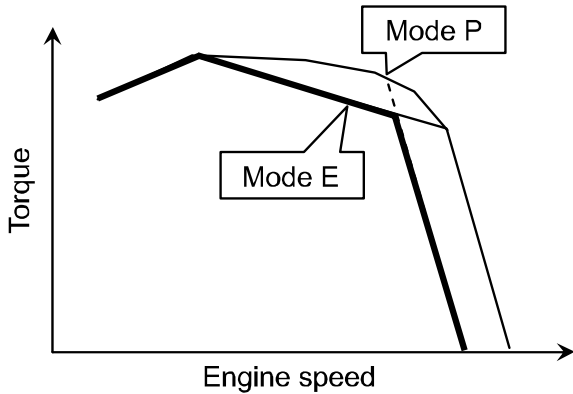

Fig. 5 Engine torque curve (Modes P and E)

(2) Low noise

Exterior noise is reduced by reducing engine operation at the rated speed (10% less compared with conventional machines), shielding the engine room, installing a variable displacement fan pump and other means. An increase in the heat balance temperature that is caused as a tradeoff is dealt with by reducing hydraulic losses through various controls, increasing air volume by hybrid fan and other measures. Through these means, the heat balance temperature could be lowered compared with conventional models to enhance the heat-resistance reliability of work equipment.

3.4 Enhanced Comfortability

(1) Reduction in noise at the operator's station

In addition to the viscous mount of the cab and rubber mounts on the hydraulic piping and valves, the sealing property of ducts for wire harnesses and under floor pipes is improved and the window opening and closing structure changed to improve the cab noise insulation property and air tightness. These measures have helped reduce the noise at the operator's station.

(2) Large armrests with adjusting mechanism

While in operation, the wheel dozer performs work at a high vehicle speed while the entire vehicle moves, significantly tiring the operator. There have been strong requests to improve the operator seating, especially for the large class dozers, which must be frequently used for many hours.

In response, large armrests with an adjusting mechanism that can optionally adjust the seat position forward and backward, as well as its height and angle are installed, plus large air suspension type seats. (Photo 4)

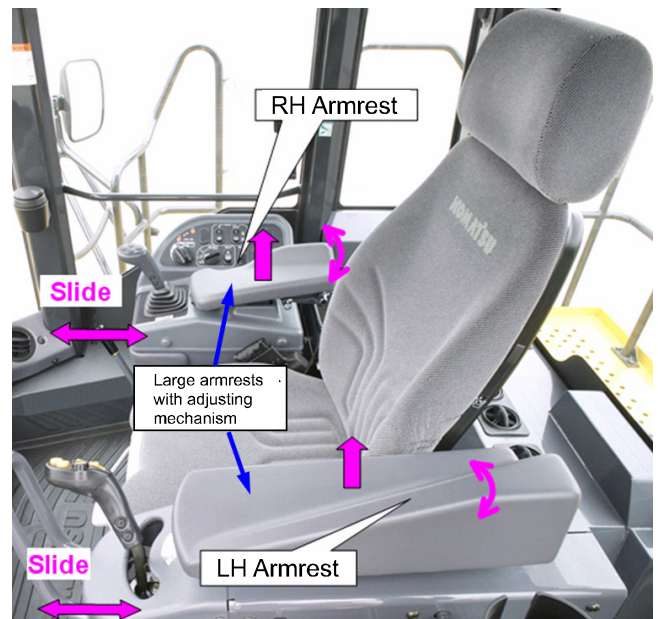

Photo 4 Large armrests with adjusting mechanism

3.5 Enhanced Safety

(1) Large ROPS cab

A large Roll-over Protective Structure (ROPS) cab, which is 16% larger in volume compared with conventional cabs, is installed to provide an interior allowing even large build operators to comfortably drive dozers. The front side of the cab has a larger glass pane compared with that of conventional models to enhance upward and downward visibility.

The rear side of the cab is fitted with a heated rear windshield embedded with a heat wire to easily clear fogging and frosting on the glass surfaces for enhanced rear visibility.

(2) Rear access ladder

A rear access ladder is installed to facilitate entry and exit to/from the cab safely and easily, while a step light is also installed in its upper section for safety when entering and exiting to/from the cab at night. **(Photo 5)**



Photo 5 Step light and rear access ladder

3.6 IT Systems

(1) EMMS (Equipment Management Monitoring System)

The monitoring panel includes failure diagnosis and maintenance management functions that display failure codes and the machine maintenance condition on the character display located in the lower middle of the main monitor as necessary.

The designs of gauges such as those for the water temperature and torque converter oil temperature have been modified compared with those for conventional models since good visibility is required for large vehicles. An eco indicator, which lights a green lamp in accordance with the extent to which the accelerator pedal is depressed, is also installed inside the monitoring panel. **(Photo 6)**



Photo 6 Eco indicator

When the Vehicle Health Monitoring System (VHMS) is installed on the dozer as an option, the operating frequency of the eco indicator and fuel consumption data are supplied in sets to be the supervisor for use in guiding operators during dozer operation.

(2) VHMS (Option)

The Vehicle Health Monitoring System (VHMS) that is useful in preventive maintenance is installed to facilitate failure diagnosis and vehicle management. The VHMS controller centrally manages the controllers that control the major components of vehicles in real-time and downloads data to a personal computer. By continuously monitoring and following up data, measures for preventive maintenance can be taken to deal with vehicle failures. If a satellite communication function is provided, vehicle information can be obtained in real-time through WebCARE or KOMTRAX.

3.7 Enhanced Maintainability

(1) Modular radiator core

The radiator core is divided into modular units to improve maintainability, which means only the necessary unit need to be extracted without having to remove the radiator guard when repair of the core is necessary. (Fig. 6)

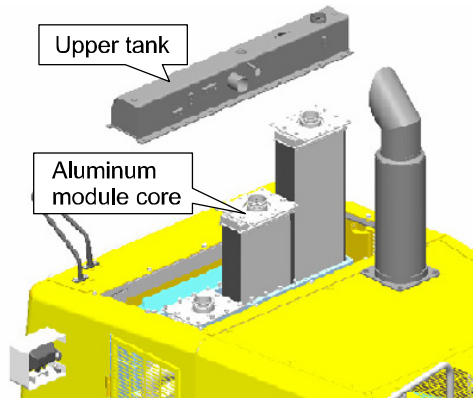

Fig. 6 Modular radiator core

(2) Hydraulic drive fan

A reversing fan function is used to dislodge clogged foreign matter in the radiator core. The mount bracket of the hydraulic drive fan is of the swing type, meaning the core can also be cleaned by high pressure water jet cleaning from inside during maintenance servicing or other circumstances. The core can be cleaned easily by removing the fan net. (Photo 7)



Photo 7 Hydraulic drive fan

4. Conclusion

Thanks to their high quality and reliability, conventional models have been well-evaluated in the market. Through this development project, enhanced mobility and economy, as well as comfortability and safety, could be achieved compared with conventional models in addition to compliance with the Tier 3 emission regulation.

The writers are confident that the evolution of the WD600-6 will also see it evaluated by users even more highly.

Introduction to the writers



Keiichi Mokka

Entered Komatsu in 1970.
Currently assigned to the Construction Equipment Technical Center 2, Development Division.

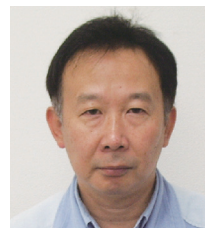

Kaichi Endo

Entered Komatsu in 1983.
Currently assigned to the Construction Equipment Technical Center 2, Development Division.

[A few words from the writers]

The time allowed for the completion of this development project was short, to meet market demands. However, the challenge was made to develop a new electric mono lever with an electric detente and a new hydraulic control mechanism and eliminate the flow concentration and dividing valve. Thanks to cooperation from other departments, the target QCD (quality, cost and delivery due date) could be met.

The writers would like to sincerely thank those in the related departments for their cooperation in making this development project a success.