

## Introduction of Product

# Introducing Electric-powered Forklift Truck “New ARION” Series

Masashi Yoshida

Yasuo Tsukamoto

Tsuyoshi Matsuda

Yoshihiro Dougan

Kazunori Ueno

*Electric-powered forklift trucks in the “New ARION” series have been developed and introduced to the market based on the concepts of “Tough & Economical,” “Safety” and “Comfort”. The background to the development, as well as the features and technologies of the new series, are described.*

**Key Words:** *New ARION, Dual drive & total AC, Totally enclosed wet-type disc brake, thorough safety design, comfortable operability lessening operator fatigue, electric hybrid forklift first in the world*

## 1. Introduction

Prompted by laws and regulations including revision of the Law concerning the Rational Use of Energy, a reduction in exhaust gas emissions has today become an urgent task at the distribution sites out of consideration to the earth’s environment.

The recent rapid rise in the price of fossil fuels is greatly impacting the management of enterprises. Partly accelerated by these backgrounds, in 2006, the proportion of electric-powered forklifts in total sale of forklifts in Japan stood at 47.9% (source: Japan Industrial Vehicles Association), accounting for nearly half of the total sales. This proportion has been increasing each year.

It is against this backdrop that four-wheel type (Type E4, **Photo 1**) and three-wheel type (Type E3, **Photo 2**) electric-powered forklifts have been introduced into the market simultaneously. The new types have undergone a full model change for the first time in eight years, aimed at environmentally friendly and safety oriented electric-powered forklifts with a mobility equal to that of engine-powered forklifts. An overview of the new forklifts is described below.



**Photo 1** FB15-12(E4) 1.5 counter four-wheel type



**Photo 2** FB15M-12(E3) 1.5 counter three-wheel type

## 2. Aim of Development

The “New ARION” has been developed for safe use even at heavy duty operation, where engine-type forklifts are used, as environmental measures at distribution sites are taken. The keynote for truck design is a low silhouette and has been considered to frequent getting on and off, turning stability at high lift position that are indispensable to electric-powered trucks.

## 3. Product Lineup and Common Design (Table 1, Fig. 1)

A compact 2-ton truck has been added to the lineup as the world’s first electric hybrid truck. Through concurrent development and common design, the number of major parts has been reduced to about 1/3.

Table 1 Product lineup

Rated capacity	1000kg	1250kg	1350kg	1500kg	1600kg	1750kg	1800kg	2000kg
4 wheels	○		○	○		○		○
4 wheels long-hour operation				○		○		○
<b>4 wheels hybrid</b>				○		○		○
3 wheels	○	○		○		○		○

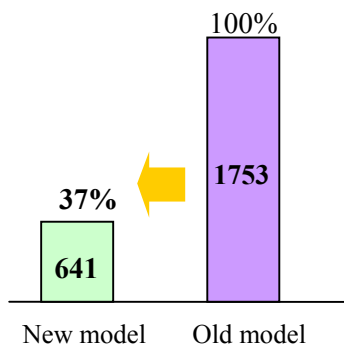


Fig. 1 Number of major parts

## 4. Appearance Design (Fig. 2)

Featuring a low silhouette and a wave line accentuating a wide open step as a keynote, the overall design highlights a stability and powerfulness by rounded the bottom part of the counterweight.



Fig. 2 Appearance design

## 5. Principal Features

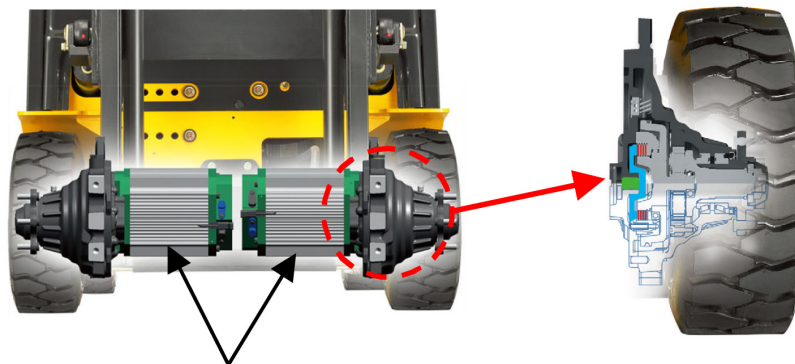
1) Mobility free from weather and road surface conditions (Fig. 3)

- Dual drive and total AC

Two totally enclosed traction motors eliminating entry of water and dust into them are directly coupled to the left and right front wheels for control of the wheels as a dual drive system. This drive system ensures excellent traveling performance and straight travel on a road covered with snow, on a slippery and wet road, or on a bumpy road. Moreover, AC control is adopted to the handling system in addition to the conventional AC traveling system. It gives reducing the cost for periodical part replacement.

- Totally enclosed wet-type disc brakes

Totally enclosed wet-type disc brakes having excellent waterproof and durability are adopted to enable safe and dependable braking in outdoor traveling also. As in the traction motors, the disc brakes excel in waterproof and dustproof performance, outputting dependable braking power in fishing ports, markets, cold storage warehouse and other places that are easily wetted with water. The brakes feature a durability in excess of 10,000 hours (tested by Komatsu), reducing the maintenance cost.



Totally enclosed traction motors

Fig. 3 Dual drive axle (Wet-type disc brakes contained)

2) Thorough safety design

- High mount rear axle (4-wheel type, Fig. 4)

The height of the connecting part between the rear axle and chassis has been raised, thereby reducing the lateral swing distance of the truck body to about half compared with conventional models, to further reduce wobbling during turning or when the forks are lifted high. The battery is placed in a low position and low profile tires with a high road surface gripping strength are adopted. Its position and flat tires ensure safe and stable turning even in narrow places.

- Operator presence sensing system (Fig. 5)

To further ensure operator safety, this feature has been incorporated ahead of the enforcement of the ISO 3691-1 safety standard, which is expected to be revised. The fork and mast does not activate when the operator is unseated. The drive of the traveling system also stops automatically. This feature will prevent accidents such as a hand or a finger being trapped by the mast and careless errors.

3) Comfortable operability to lessen fatigue

- Combination lever (Fig. 6)

At more sites, electric-powered trucks are now performing harsh work that has been performed by engine-type forklifts and the operators of electric-powered trucks are requesting lessening of work stresses caused when operating electric-powered trucks. The handling control lever that was located by the steering wheel away from the operator is now placed on the right side of the operator in the new ARION. The forward-reverse switch is embedded in the handling control lever. This allows load handling and forward-reverse switching with a minimum of motion, by significantly reducing operator fatigue during continuous work.

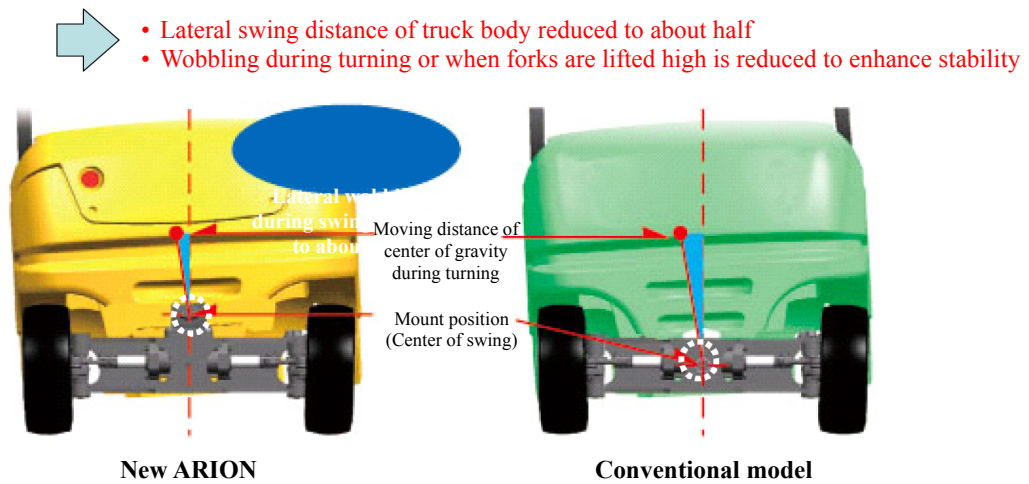
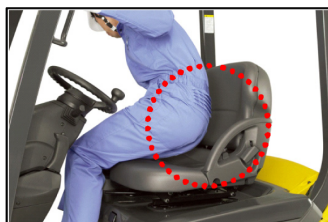


Fig. 4 High mount rear axle

ISO 3691-1 safety standard, which is expected to be revised, is complied with in advance



When the operator is unseated,

- Mast and forks stop automatically
- Drive of traveling system is also stopped automatically



This feature prevents accidents such as hand or a finger being trapped, sudden starts and crash

Fig. 5 Operator presence sensing system

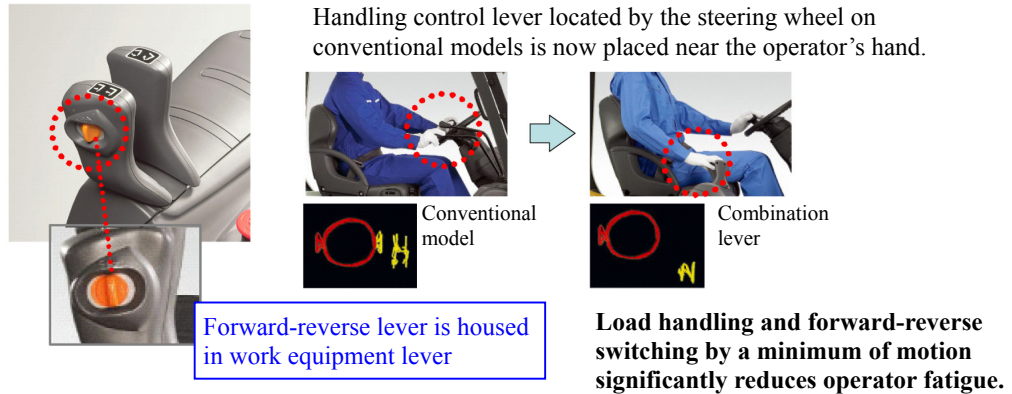


Fig. 6 Combination lever

• Proportional solenoid valve control (Figs. 7 and 8)

This function controls hydraulic pressure of the handling equipment by means of computer control to smoothen start and stop of lifting/lowering operation. The function mainly reduced swinging of the forks and truck body caused by inching movement of the forks, to prevent collapsing of the load and to lessen stresses on the operator whose attention is focused on the load.

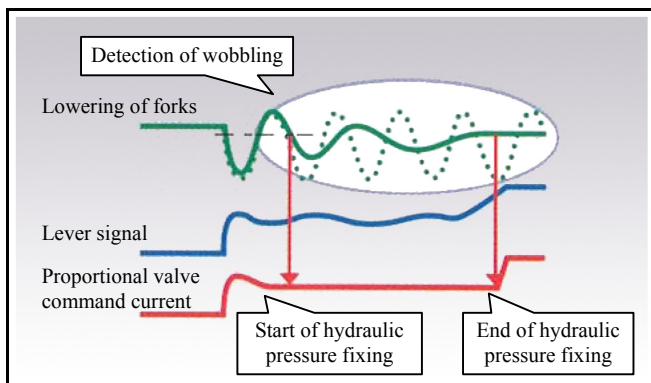


Fig. 7 Electronic control of proportional solenoid valve

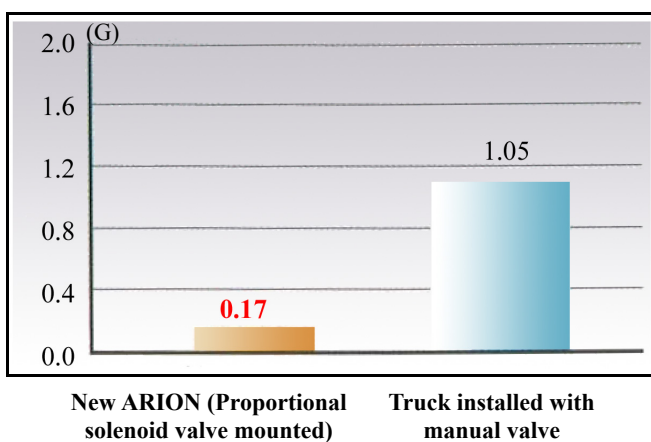


Fig. 8 Improvement of shock on stop of lowering of forks without load

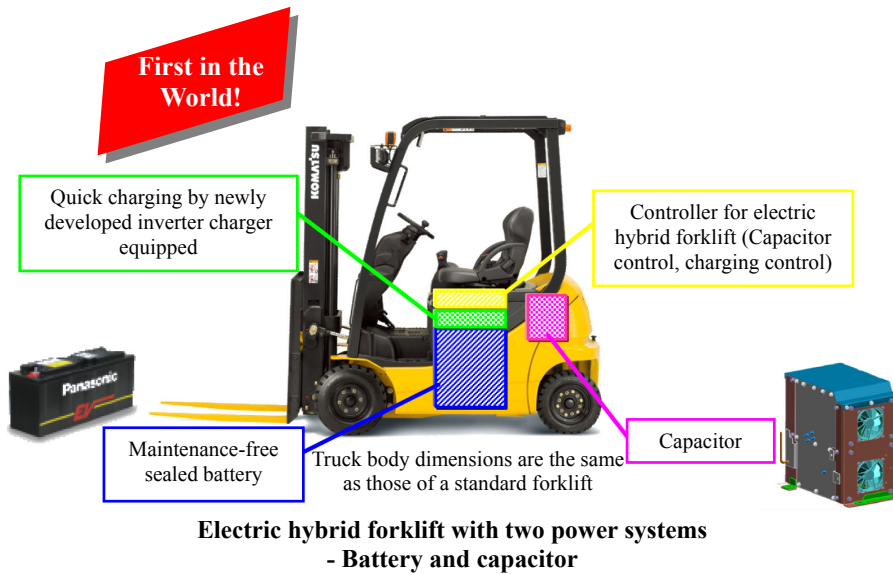
4) Electric hybrid forklift first in the world (Photo 3)

The electric hybrid forklift has two power source systems, namely, a battery as the conventional energy power source and a capacitor as a power source of the power type. An built-in quick charger and controller for the hybrid system are equipped to utilize this system. A sealed battery that does not require refilling of water and AC motors make the truck maintenance free.

The capacitor and quick charger solve the weak points of conventional electric-powered trucks, namely, “load handling power” and “long-hour operation.” The new ARION forklifts are energy-saving forklifts that save a maximum 20% of power in power consumption compared with a standard-type forklift (Fig. 9).

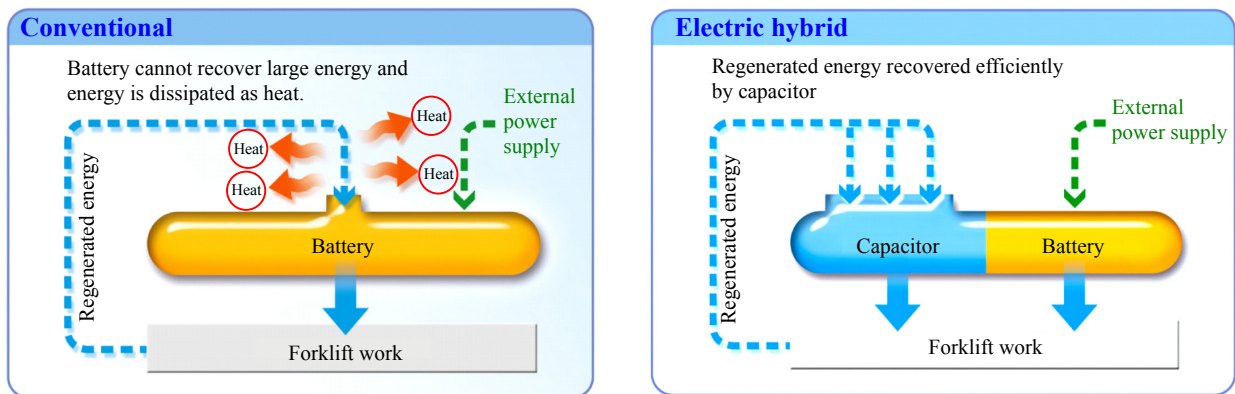


Photo 3 FB15HB-12 (HYBRID) 1.5-ton battery hybrid forklift



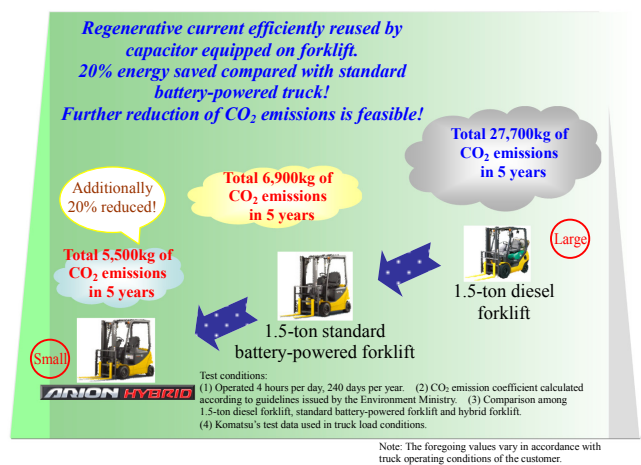
**Electric hybrid forklift with two power systems - Battery and capacitor**

**Fig. 9** Structure of electric hybrid forklift



**Fig. 10** Mechanism of energy recovery

- Features of electric hybrid forklift (**Figs. 10 and 11**)
  - (1) Energy saving maximum 20%, CO<sub>2</sub> reduced 20%
  - (2) No power down
    - No power down caused by low battery power at higher discharged stage as in conventional electric-powered trucks
    - Higher work efficiency
  - (3) Long-hour operation by quick charging
    - Free from worries about sudden calls for overtime work, forgetting to charge and in other events
    - Continuously operated for 11 hours at the most without charging
  - (4) Sealed battery is adopted, preventing from forgetting to refill water
    - Cumbersome refilling of water is not required
    - Free from worry about battery deterioration caused by forgetting to refill water



**Fig. 11** Reduction of CO<sub>2</sub>

## 6. Conclusion

Since it was introduced into the market in January 2007, the ARION type 12 has become a popular truck thanks to its dual drive wet-type disc brakes that are not found in other trucks. The production level of ARION type 12 is kept more than twice that compared with that of last year.

The electric hybrid forklift introduced in May is also enjoying very high reputation. As the earth environment deteriorates, we are striving to develop electric-powered forklift of higher performance and more energy saving under the catch phrase of “Competitors are engine powered forklifts.”

### Introduction of the writer



#### **Masashi Yoshida**

Entered Komatsu in 1975.  
Currently assigned to Utility Equipment  
Technical Center 2, Development  
Division, Komatsu Utility Co., Ltd.



#### **Yasuo Tsukamoto**

Entered Komatsu in 1973.  
Currently assigned to Utility Equipment  
Technical Center 2, Development  
Division, Komatsu Utility Co., Ltd.



#### **Tsuyoshi Matsuda**

Entered Komatsu in 1985.  
Currently assigned to Utility Equipment  
Technical Center 2, Development  
Division, Komatsu Utility Co., Ltd.



#### **Yoshihiro Dougan**

Entered Komatsu in 1989.  
Currently assigned to Utility Equipment  
Technical Center 2, Development  
Division, Komatsu Utility Co., Ltd.



#### **Kazunori Ueno**

Entered Komatsu in 1990.  
Currently assigned to Utility Equipment  
Technical Center 2, Development  
Division, Komatsu Utility Co., Ltd.

### [A few words from the writer]

One morning in February of this year, a distributor reported that a customer in the snowy Joetsu region had phoned them excitedly to say “This vehicle runs through snow without chains strapped to the tires!” The hearts of all the members of the development team were warmed by this message. We wish to continue developing “heart warming” products.