

# Introduction of High Output Engine SAA12V140 for Generator

Jun Fuchisawa

*As one of the products of our diesel engine series for stationary continuous power generators, the SA12V140 engine has been manufactured for generators whose output range is 500ekW. Recently, we developed a high output engine, SAA12V140, for stationary continuous power generators of 800/700ekW output range.*

**Key Words:** *Engine for Stationary Continuous Power Generator, Higher Output, Lightweight and Compact, Good Fuel Efficiency*

## 1. Introduction

For many of stationary continuous power generators of 800/700ekW output range, a large diesel engine of low- to medium-speed has been used. Komatsu too manufactures the 46-liter diesel engine, SA12V170, for generators of the above output range. However, a large diesel engine, like SA12V170, requires a considerable initial cost because of the difficulty involved in mounting it onto the generator package and installing it. The high initial cost, together with the high running cost, makes it difficult to secure the advantages of the power generating equipment. This has been an impediment to the promotion of sales of large, stationary continuous power generators in the face of the liberalization of electricity retail.

Recently, in order to meet the demand for lower initial cost and lower running cost of stationary generators, we developed a new, high output engine, SAA12V140, for stationary continuous power generators of 800/700ekW output range. Based on the existing SA12V140 engine that has been used for stationary continuous power generators of 500ekW output range, the newly-developed engine that features higher output and reduced impact on the environment incorporates a number of Komatsu's advanced technologies, including the electronically-controlled, high-pressure fuel injection pump, high-efficiency turbocharger, and air-cooling aftercooler. This paper describes the newly-developed SAA12V140 engine.

## 2. Aims of development

The SAA12V140 engine that shares the main components with the existing SA12V140 engine for stationary continuous power generators of 500ekW output range and that is comparable in reliability and durability to the SA12V140 was developed with the following items as the main quality targets.

- ① Increasing engine output: Attaining a generator output of 800/700ekW (increasing engine output by 40% and securing engine performance, reliability, and durability comparable to those of SA12V140)

- ② Complying with the Air Pollution Control Law (NOx: max. 950ppm/standard for inspection during factory shipment: max. 760ppm)
- ③ Improving fuel efficiency: Reducing fuel consumption by 3% as compared with the existing SA12V140
- ④ Reducing the black smoke during operation and the white smoke at cold start: Emissions of black smoke/white smoke not more than those of the existing SA12V140

## 3. Features of newly-developed SAA12V140 engine

**Photo 1** shows the appearance of the SAA12V140 engine, and **Table 1** compares the performances between the new and existing engines.

**Fig. 1** shows the principal measures taken to attain the aims of development of the SAA12V140 and the contents of modifications to the SA12V140.

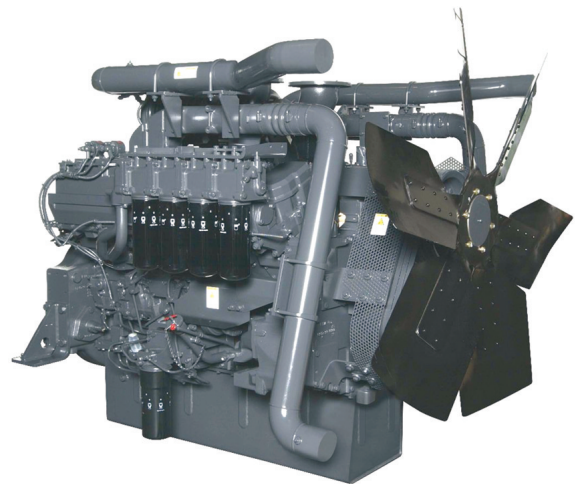

**Photo 1** Appearance of SAA12V140

**Table 1** Performance comparison (newly-developed engine vs. existing engines)  
700/800ekW                      500ekW                      700/800ekW

|                                                  | Newly-developed engine |            | Existing engine    |            | Existing engine    |            | Remarks                  |
|--------------------------------------------------|------------------------|------------|--------------------|------------|--------------------|------------|--------------------------|
| Type                                             | SAA12V140              |            | SA12V140           |            | SA12V170           |            |                          |
| Number of cylinders                              | 12                     |            | 12                 |            | 12                 |            |                          |
| Bore(mm)                                         | 140                    |            | 140                |            | 170                |            |                          |
| Stroke(mm)                                       | 165                    |            | 165                |            | 170                |            |                          |
| Displacement( $\ell$ )                           | 30.5                   |            | 30.5               |            | 46.3               |            |                          |
| Frequency                                        | 50Hz                   | 60Hz       | 50Hz               | 60Hz       | 50Hz               | 60Hz       |                          |
| Rated output(PS)                                 | 1038                   | 1197       | 752                | 846        | 1127               | 1256       | PS with fan              |
| Rated output(mkW)                                | 763                    | 880        | 553                | 622        | 829                | 924        | (Equipped with radiator) |
| Generator efficiency                             | 0.93                   | 0.93       | 0.93               | 0.93       | 0.93               | 0.93       |                          |
| <b>Rated output(ekW)</b>                         | <b>710</b>             | <b>819</b> | <b>514</b>         | <b>579</b> | <b>771</b>         | <b>859</b> |                          |
| Fuel efficiency at rated rpm(g/PSh)              | 150                    | 151        | 155                | 161        | 159                | 168        |                          |
| <b>Fuel efficiency at rated rpm(g/kWh)</b>       | <b>204</b>             | <b>205</b> | <b>211</b>         | <b>219</b> | <b>216</b>         | <b>228</b> |                          |
| Hourly fuel consumption at rated rpm( $\ell$ /H) | 183                    | 213        | 137                | 160        | 211                | 248        |                          |
| Exhaust gas color(BSU)                           | 0                      | 0          | 0.4                | 0.3        | 0.4                | 0.4        |                          |
| NOx (ppm)                                        | Max. 950               | Max. 950   | Max. 950           | Max. 950   | Max. 950           | Max. 950   |                          |
| Air Pollution Control Law                        | Complied               |            | Complied           |            | Complied           |            |                          |
| Approximate dimensions (mm) *1                   | 2050 × 1702 × 1853     |            | 2050 × 1530 × 1812 |            | 2697 × 1500 × 1950 |            |                          |
| Volume (m <sup>3</sup> ) *1                      | 6.47                   |            | 5.68               |            | 7.89               |            |                          |
| Dry mass (kg) *1                                 | 3490                   |            | 3200               |            | 5450               |            |                          |

\*1: Figures are for the engine proper (with fan), excluding the radiator-related parts.

Legend

|         |     |
|---------|-----|
| Purpose |     |
| Item    | Aim |

- Measure to improve fuel efficiency
- Measure to reduce environmental impact
- Measure to improve durability/reliability

|  |                                                                                                                                                                                 |                                                                                    |
|--|---------------------------------------------------------------------------------------------------------------------------------------------------------------------------------|------------------------------------------------------------------------------------|
|  | Reducing emission of white smoke at cold start                                                                                                                                  |                                                                                    |
|  | Adopting system for heating suction air after engine is started<br>(After engine start is detected, electric current passed to suction air heater is controlled automatically.) | In cold weather, air let into cylinders is warmed to promote vaporization of fuel. |

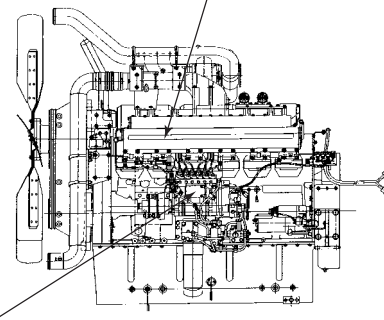
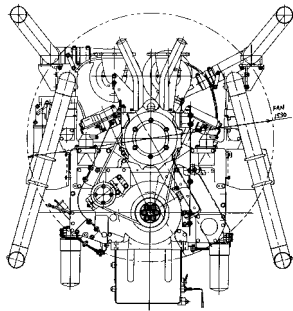

|  |                                                   |                             |
|--|---------------------------------------------------|-----------------------------|
|  | Adopting high-efficiency, air-cooling aftercooler |                             |
|  | Lowering suction air temperature (aim: 50 °C)     | To reduce exhaust emission. |
|  | Increasing suction air density                    | To increase engine output.  |
|  | Improving radiator specifications                 |                             |
|  | Increasing radiating area of radiator             | To increase engine output.  |

|  |                                                                                             |                                                                             |
|--|---------------------------------------------------------------------------------------------|-----------------------------------------------------------------------------|
|  | Improving fuel efficiency and reducing black smoke emission                                 |                                                                             |
|  | ① Adoption of Komatsu in-line fuel injection pump KP21 (electronically-controlled governor) | To ensure optimum injection timing and permit high-pressure fuel injection. |
|  | ② Adoption of fluid-polished injection nozzle                                               | To refine fuel mist.                                                        |
|  | ③ Control of acceleration from Li to Hi                                                     | To reduce emission of black smoke during sudden acceleration.               |

|  |                                                     |                                                        |
|--|-----------------------------------------------------|--------------------------------------------------------|
|  | Adopting high-efficiency turbocharger (HOLSET HX82) |                                                        |
|  | Blower of large flow rate                           | To increase engine output and improve fuel efficiency. |
|  | 50/60 Hz turbocharger                               | To optimize engine performance.                        |

|  |                                                                           |                                                                                                                                               |
|--|---------------------------------------------------------------------------|-----------------------------------------------------------------------------------------------------------------------------------------------|
|  | Reducing cost incurred by customer and enhancing user interface functions |                                                                                                                                               |
|  | Adoption of Komatsu electronic governor controller                        | To simplify controller exclusive for grid connection to commercial power supply.<br>To diagnose and display trouble with electronic governor. |

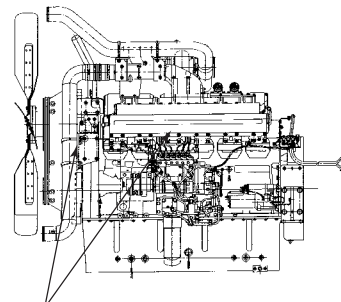
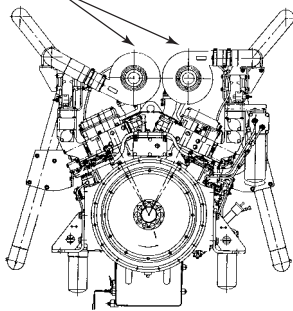

|  |                         |                                  |
|--|-------------------------|----------------------------------|
|  | Increasing safety       |                                  |
|  | Insulating hot parts    | To secure high degree of safety. |
|  | Covering rotating parts |                                  |

|  |                                                                      |                                                                                              |
|--|----------------------------------------------------------------------|----------------------------------------------------------------------------------------------|
|  | Adopting large-capacity oil pan, full-flow filter, and bypass filter |                                                                                              |
|  | Increasing amount of oil                                             | To secure aimed reliability and durability.<br>To prolong period of oil change to 500 hours. |

**Fig. 1** Principal measures taken with new engine to attain aims of development and contents of modifications made to existing engine

**3.1 Improvements in performance as compared with existing engines**

As shown in Table 1, the newly-developed SAA12V140 engine has attained the following improvements in performance.

- ① As compared with the existing SA12V140 engine for 500ekW output range, the SAA12V140 is 3% to 6% better in fuel efficiency.
- ② As compared with the existing SA12V170 engine for 800/700ekW output range, the SAA12V140 is better in fuel efficiency (fuel consumption about 5% smaller), lighter in weight, and more compact in size (volume about 18% smaller).

**3.2 Principal measures taken to attain aims of development and contents of modifications made to existing engine**

(1) Adopting a high-efficiency turbocharger of large flow rate  
 In order to increase the engine output and improve the fuel efficiency, the conventional Komatsu KTR110 turbocharger was replaced with Holset's HX82 turbocharger that has higher efficiency and larger flow rate.

(2) Adopting an air-cooling aftercooler  
 In order to minimize the increase in thermal load due to an increase in engine output (to secure reliability) and reduce the exhaust emission, a high-efficiency, air-cooling aftercooler was adopted. This aftercooler, which lowers the boost temperature of about 180°C to the suction air temperature of 50°C or less at the outlet, has made it possible to reduce the exhaust emission while increasing the engine output.

(3) Adopting Komatsu's electronically-controlled, high-pressure fuel injection pump (KP21)

The existing engines for continuous power generators already employ an electronic governor-controlled fuel injection pump of RBAJ. In order to increase the fuel injection rate for higher engine output and reduce the exhaust emission and the white smoke at cold start, the new engine required variable control of the optimum fuel injection timing. Therefore, the Komatsu's electronically-controlled fuel injection pump (KP21) that is capable of the required variable control was adopted (Fig. 2).

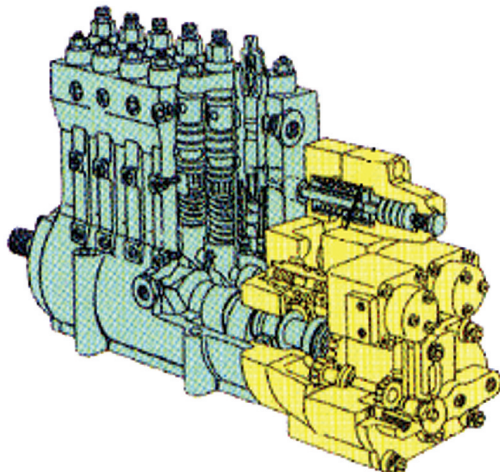

Fig. 2 KP21 fuel injection pump

With this fuel injection pump, the optimum fuel injection timing for steady-state operation and cold start, respectively, is determined by a map on the program of the Komatsu's controller (LE controller) to reduce both the exhaust emission during steady-state operation and the emission of white smoke at cold start.

(4) Optimizing the fuel injection nozzle

In order to reduce the consumption of fuel and the emission of black smoke, a fluid-polished nozzle with two stages of nozzle holes developed by Komatsu was adopted to minimize the nozzle hole diameter and refine the fuel mist.

- ① Adoption of nozzle with two stages of holes for fuel injection
  - A two-stage fuel injection nozzle, each stage having six holes, was adopted to improve the injection performance.
  - The increased number of nozzle holes, together with the high-pressure fuel injection by the injection pump, refines the fuel mist. Therefore, despite the fact that the engine output was increased, good fuel efficiency and satisfactory exhaust color could be secured (Fig. 3).

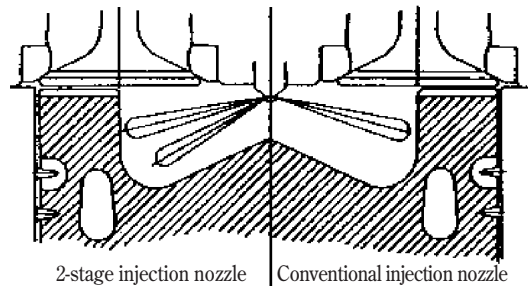

Fig. 3 2-stage injection nozzle

- ② Adoption of fluid-polished injection nozzle
  - The flow coefficient was increased by rounding the edge of each of the inner nozzle holes by passing high-pressure abrasive fluid through the nozzle (this permits reducing the nozzle hole diameter for a given flow rate) (Fig. 4).
  - Since the fluid-polished nozzle refines the fuel mist injected, good fuel efficiency and satisfactory exhaust color could be secured.

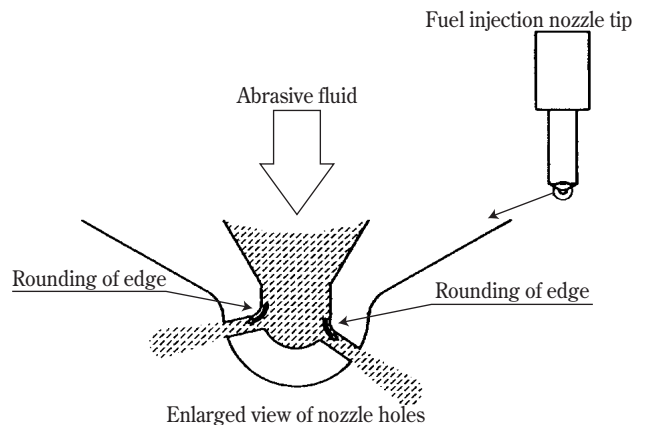

Fig. 4 Fluid-polished fuel injection nozzle

(5) Increasing the oil pan capacity

In order to prolong the period of oil change (when A-heavy oil is used) to 500 hours, the oil pan capacity was increased from 132/85 ℓ (H/L level) to 182/85 ℓ (H/L level).

(6) Applying electronic control technology

The existing engines for stationary continuous power generators employ an electronic governor-controlled injection pump to take advantage of the advanced engine control technology.

This is also advantageous from the standpoint of enhancing the user interface functions (e.g., troubleshooting by processing of signals from the generator). The outline of the engine control system is shown in Fig. 5, and the contents of control by the electronic governor are shown in Table 2.

The control functions shown in Table 2 are also incorporated in the Komatsu electronic governor controller (LE controller) that is adopted for the newly-developed engine. In addition, the following two control logics have been adopted to reduce the emissions of black smoke and white smoke.

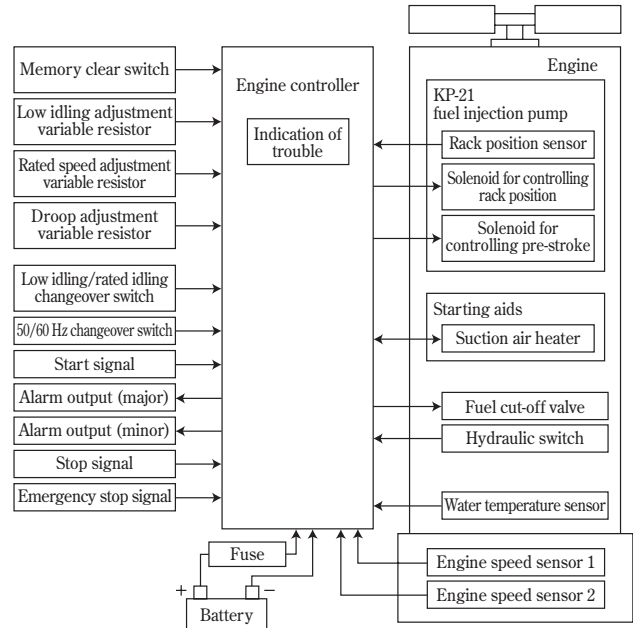

Fig. 5 Engine control system

Table 2 Contents of control of electronic governor

| No. | Item                                                                                              | Content                                                                                                                                                                                                                                                                         |
|-----|---------------------------------------------------------------------------------------------------|---------------------------------------------------------------------------------------------------------------------------------------------------------------------------------------------------------------------------------------------------------------------------------|
| 1   | Frequency (50/60 Hz) changeover                                                                   | Switching between 50 Hz and 60 Hz by turning on/off jumper wire on panel. Switching is disabled during operation (it is possible only when power supply is off).                                                                                                                |
| 2   | Li/rated operation changeover                                                                     | Switching between Li speed and rated speed by putting in switch signal from generator operation panel. This is possible only during operation (power supply on).                                                                                                                |
| 3   | Li speed adjustment                                                                               | Adjustment of Li speed by variable resistor on panel. Adjustable range: 800 rpm ± 100 rpm                                                                                                                                                                                       |
| 4   | Droop/isochronous operation changeover                                                            | Switching of rated speed control method between droop control (No. 5) and isochronous control (No. 6) by turning on/off jumper wire on panel. Switching is disabled during operation (it is possible only when power supply is off).                                            |
| 5   | Droop-controlled operation                                                                        | When droop/isochronous changeover jumper wire (No. 4) is in DROOP position, droop-controlled operation (engine speed varies according to load) is performed. Speed is adjusted by pulse signal (No. 7), analog signal (No. 9), or variable resistor (No. 8) on panel.           |
| 6   | Isochronous-controlled operation                                                                  | When droop/isochronous changeover jumper wire (No. 4) is in ISOCHRONOUS position, isochronous-controlled operation (rated speed is invariable regardless of load) is performed. Speed is adjusted by analog signal (No. 9) or variable resistor (No. 8).                        |
| 7   | Rated speed adjustment by pulse signal (during droop control)                                     | Rated speed is adjusted by pulse signal input from generator panel. Adjustable range: ±3 rpm/sec (normal) Criterion: 50msec                                                                                                                                                     |
| 8   | Rated speed adjustment by variable resistor (during isochronous or droop control)                 | Rated speed is adjusted by variable resistor on panel.                                                                                                                                                                                                                          |
| 9   | Rated speed adjustment by analog signal input (during isochronous or droop control)               | Rated speed is adjusted by analog signal input from generator panel. Speed control signal range: 1 to 4 V DC                                                                                                                                                                    |
| 10  | Speed adjustment analog/pulse signal changeover (during droop control)                            | Switching of rated speed adjustment method between pulse signal input (No. 7) or analog signal input (No. 9) by turning on/off jumper wire on panel. Switching is possible even during operation (power supply on).                                                             |
| 11  | Speed adjustment analog signal/variable resistor changeover (during isochronous or droop control) | Switching of rated speed adjustment method between variable resistor adjustment (No. 8) and analog signal input (No. 9) by turning on/off jumper wire on panel. Switching is possible even during operation (power supply on), although error message may be displayed.         |
| 12  | Droop adjustment (during droop control)                                                           | Regulation is varied by variable resistor on panel during operation at rated speed. Adjustable range: approx. 3% to 5%                                                                                                                                                          |
| 13  | Control of sudden acceleration (speed lamp)                                                       | When Li/rated speed changeover switch is in Rated Speed position, time in which Li speed is increased to rated speed is controlled to reduce occurrence of smoke due to sudden acceleration. Same control is possible even without Li (Start → Hi).                             |
| 14  | Speed ramp on/off changeover                                                                      | Whether to implement control of sudden acceleration (No. 13) is determined by turning on/off jumper wire on panel. Switching is disabled during operation (it is possible only when power supply is off).                                                                       |
| 15  | Stop function                                                                                     | Engine is stopped safely by stop signal input.                                                                                                                                                                                                                                  |
| 16  | Emergency stop function                                                                           | Emergency stop of engine is effected in case of major trouble (oil pressure drop, water temperature rise, excessive speed, etc.) or by external signal.                                                                                                                         |
| 17  | Troubleshooting & display function                                                                | In case of trouble with electronic governor system, prescribed anomaly processing is performed and fault signal is put out. Output: error code displayed on controller panel and presence or absence of anomaly indicated by lamp (For details, see the Troubleshooting List.). |
| 18  | Memory clear function                                                                             | Error code stored in memory is erased by pushing Memory clear button on panel.                                                                                                                                                                                                  |
| 19  | Over-speed mode changeover (used only for testing)                                                | Over-speed test is enabled by jumper wire on panel. Switching is disabled during operation (it is possible only when power supply is off).                                                                                                                                      |
| 20  | PID adjustment function                                                                           | It is possible to change control constant by variable resistor on panel so as to permit setting optimum stability and response of generator (only during operation at rated speed).                                                                                             |
| 21  | PID adjustment on/off changeover                                                                  | Whether to fine-adjust PID constant by variable resistor on panel or use internal data (fixed) is determined by turning on/off jumper wire on panel. Switching is disabled during operation (it is possible only when power supply is off).                                     |
| 22  | Speed relay function                                                                              | Engine start is detected and relay signal is put out.                                                                                                                                                                                                                           |
| 23  | Pre-lubrication mode function                                                                     | When Pre-lubrication switch on control panel is ON, cranking of engine without starting it is made possible. This is disabled during operation. (If the switch is turned on during operation, engine stops.)                                                                    |

① Reducing emission of black smoke during sudden acceleration

The acceleration from Li to Hi is subject to ramp acceleration control (for about 10 seconds) to control the rate of fuel injection so as to make the exhaust during sudden acceleration invisible.

② Reducing emission of white smoke at cold start

In order to reduce the emission of white smoke after starting the engine in cold weather, the LE controller is provided with an “automatic post-heating system” which, after the engine is started, energizes the suction air heater in the air intake manifold to heat the suction air. After detecting an engine start, the system controls the action of the suction air heater relay so as to reduce the emission of white smoke during the time schedule from the start of the generator to the application of load (Fig. 7). (The suction air heater is energized intermittently for a total of 300 seconds with on-off intervals of 10 seconds.)

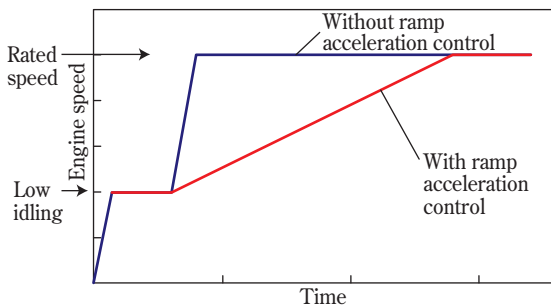

Fig. 6 Ramp acceleration control

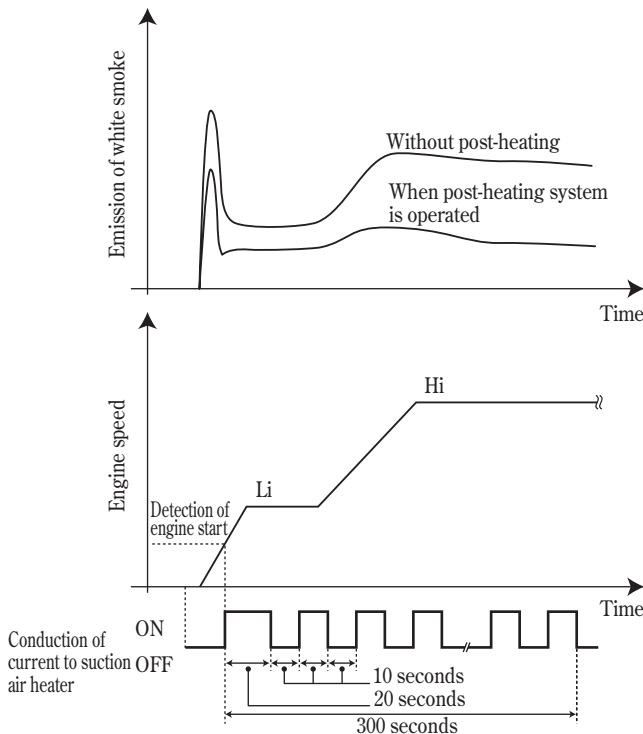

Fig. 7 Post-heating system for reducing emission of white smoke

4. Future plans

The newly-developed SAA12V140 engine that features high output, light weight, compact size, and good fuel efficiency has eliminated the disadvantages (high initial cost and high running cost) of the existing SA12V140 engine for stationary continuous power generator of the same output range. In addition, the new engine has less impact on the environment and is comparable in reliability to the existing engine. Therefore, we are confident that it will promote the sales of Komatsu engines for large, stationary continuous power generators in the future.

On the other hand, for every maker of generators, it has become an important issue to improve the efficiency of energy recovery by applying existing stationary continuous power generators not only for electricity generation but also for cogeneration (e.g., utilization of hot water and waste heat). Concerning the application of the newly-developed engine to such generators, we would like to consult with the individual generator makers on specifications and promote the sale of the engine in the future.

Introduction of the writer

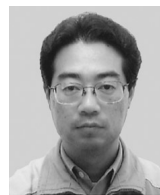

Jun Fuchisawa

Entered Komatsu in 1990. Currently working in the Applied Product Development Group, IPA Inc.

[A few words from the writer]

The Komatsu engines for generators are supplied to a number of generator makers on an OEM basis and installed in many factories, shopping centers, etc. I would like to see how the newly-developed engine will be evaluated (in comparison with the existing engine) by the generator makers. At the same time, I expect that the new engine will be well received by our customers.