

Development of New Materials for Special Oil-Impregnated Bearings

Yoshikiyo Tanaka

Masanori Ueyama

Takemori Takayama

In recent years, facilitating the maintenance of hydraulic excavators is generally considered a means of enhancing their functions. At our company too, with the aim of prolonging the greasing interval for the work equipment bushings of Model PC200-7/PC300-7/PC400-7 hydraulic excavators, we carried our research on new materials for the bushings. As a result, we could develop two types of new materials — a copper-based material (BMRC) and an iron-based material (OMRF) for oil-impregnated, self-lubricating bearing. This paper describes the newly-developed materials.

Key Words: Oil-Impregnated, Self-Lubricating Bearing, Copper Alloy, Ferrous Alloy, BMRC, OMRF, Greasing Interval, Maintenance

1. Introduction

The bushings of the work equipment of a hydraulic excavator are subject to a high surface pressure and a large offset load. As the material for the bushings, therefore, induction-hardened and cemented steel having very high strength has long been used. These bushings, however, require greasing (maintenance) before using the hydraulic excavator in order to prevent them from seizing with the work equipment pins and producing the harsh sliding sound called a squeak. With the growing demand for easier maintenance of construction equipment, it has become necessary to develop a new material for the work equipment bushings that permits prolonging the greasing interval.

Under that condition, in the process of development of the GALEO series of hydraulic excavators (PC200, PC300, and PC400), we came up with two types of new bushing materials — a copper-based BMRC having excellent resistance to seizure and an iron-based OMRF having excellent resistance to wear. This paper describes the two new materials which have been put into practical use.

2. How work equipment bushings are used and development policy

Fig. 1 shows where the work equipment bushings are used, and Fig. 2 shows the relationship between work equipment bushing surface pressure and sliding speed during excavation and dumping with a PC200. The working conditions of general-purpose, oil-impregnated bearing material are also shown in Fig. 2.

In the region in which the sliding speed is low, a seizure tends to occur easily as the oil lubrication is insufficient and the required lubricating ability can hardly be maintained under a high surface pressure. It can be seen from this fact that the

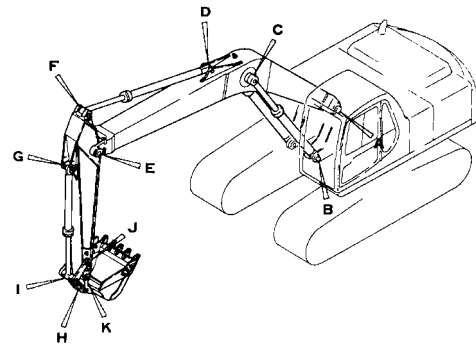

Fig. 1 Places where bushings are used

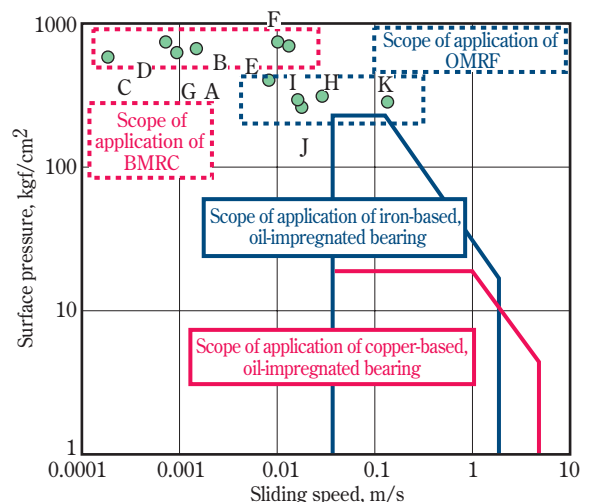

Fig. 2 Conditions under which work equipment bushings are used

work equipment bushings are used under much more grueling lubrication conditions than are the general-purpose, oil-impregnated bearings. It can also be seen that the requirement of the work equipment bushings differs according to where they are used. Thus,

- ① The bushings used at A, B, C, and D which concern the boom foot operation are required to have especially good resistance to seizure since they are subject to a very high surface pressure and lubricated poorly due to their low sliding speed.
- ② The bushings used at E, F, G, H, I, and J are required to have especially good wear resistance because of their long sliding distance, although they are lubricated a little better than the bushings mentioned above.

Therefore, we developed two types of bushing materials. They are a copper-based BMRC material which has excellent seizure resistance and hence can be used at points A, B, C, and D, and a low-cost, iron-based OMRF material which has excellent wear resistance and hence can be used at points F, G, H, I, and J.

3. Development of BMRC material

3.1 BMCR material

Photo 1 shows a microstructure of the BMCR material.

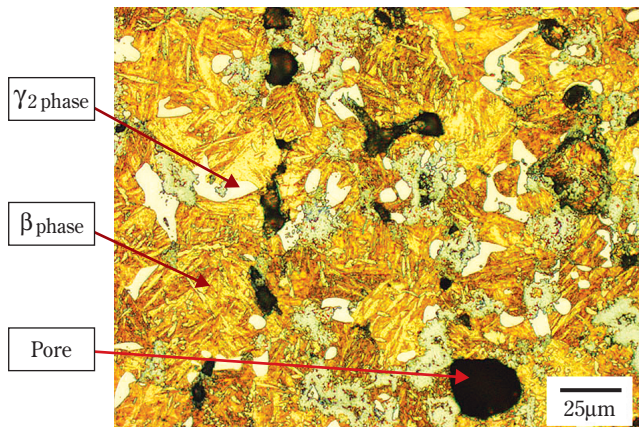

Photo 1 Microstructure of BMRC material

The parts that appear black are pores which retain oil and supply oil to the lubrication surface when sliding. The matrix is copper-aluminum based β phase. It contains hard particles of γ₂ phase, etc. in the inside.

The conventional copper-based material for oil-impregnated bearing consists of a bronze-based matrix and a lubricating part made up of pores, graphite, etc. Thus, the basic microstructure of the BMRC material is the same as that of the conventional material. The major difference is that the matrix of the BMRC material is a copper-based β phase which is very hard (Hv: 250).

The basic concept that led us to introduce a copper-based β phase is described below.

Bronze having a copper-based α phase is so soft (Hv: 110) that it is susceptible to coagulation wear. A material having this phase as the matrix does not have sufficient resistance to seizure when the sliding speed is low and the surface pressure is high.

On the other hand, we found that the copper-based β phase in which atoms of copper and aluminum are arranged regularly tends to show the behavior of an intermetallic compound and

good resistance to coagulation wear. On the basis of this finding, we developed a Cu-Al-Sn based BMRC material which has excellent wear resistance (U.S. Pat. No. 6613121).

This sliding material having a β phase which is very strong and hard is worthy of special note as it has conquered the difficulty involved in sintering Cu-Al based alloys. Sinter-joined to the stiff steel pipe interior, it is a new material for work equipment bushing developed by the company's own technology.

3.2 Characteristics of BMRC material

Table 1 shows the basic composition of the BMRC material, and Table 2 shows the mechanical properties of the material.

Table 1 Basic composition of BMRC material (wt%)

Composition	Cu	Al	Sn	Special additives
Content	Remainder	8 - 12	4 - 8	5 - 7

Table 2 Mechanical properties of BMRC material

Item	BMRC material	Conventional material (Cu-Sn based)
Tensile strength	130 - 180 MPa	100 MPa
Hardness	HRB; 70 - 90	HRB; 30 - 40
Oil content	12% - 18%	12% - 18%

It can be seen that the BMRC material is superior in hardness and strength to the conventional material.

3.3 Sinter-bonding to steel pipe interior

Photo 2 shows a microstructure of a bonding between the BMRC material and iron back plate.

The upper part is the BMRC material, and the lower part is iron.

Aluminum contained in the BMRC material was dispersed in the iron, forming an α phase in the boundary of the bonding. Therefore, the two materials are considered to have bonded together sufficiently.

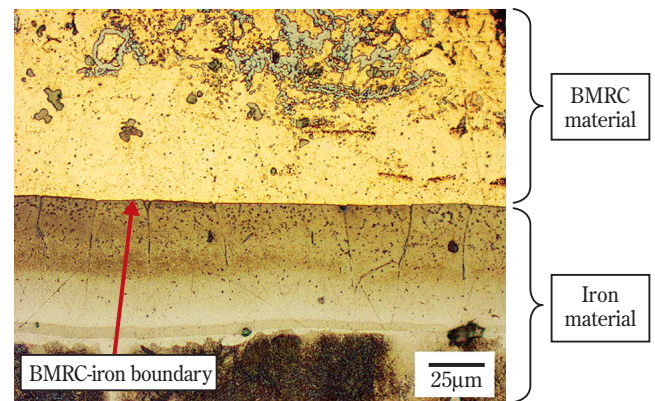

Photo 2 Bonding between BMRC material and iron material

3.4 Sliding characteristic of BMRC material

As an example of sliding characteristic, **Fig. 3** compares the resistance to seizure among the BMRC material, IQT material (induction-hardened and tempered material), and high-strength brass material used to prevent a squeak. After a sufficient amount of grease was applied to the sliding surface, the load applied was increased stepwise with the oscillating angle kept at 160 degrees (sliding speed: 0.013 m/s) and the resistance to seizure was evaluated by the load that caused a seizure. A seizure was judged to have occurred when the coefficient of friction increased to 0.3 or showed unusual behavior or when a squeaking sound was produced.

It is evident from Fig. 3 that the BMRC material having the oil impregnation function is superior in seizure resistance to the IQT material and high-strength brass material (α phase + β phase).

3.5 Results of test with actual machine

Fig. 4 shows the amount of wear of a BMRC bushing tested on a PC200 hydraulic excavator. The bushing was installed at the bottom of the boom cylinder (point B). The IQT bushing was greased every 100 hours.

The figure compares the amount of wear in 100 hours by an index. It may be said that the BMRC material is superior in wear resistance to the IQT and high-strength brass materials.

3.6 BMRC material manufacturing process

Fig. 5 shows the BMRC material manufacturing process. It consists of a process in which the powder material is mixed in a prescribed proportion and pressed into a cylinder, a process in which the formed cylinder is inserted into a cylindrical metallic tube which is machined previously, and a process in which the sliding part is sintered and bonded to the metal. The sintered product is subjected to a bonding test by ultrasonic wave (ultrasonic test) and finished by machining.

Photo 3 shows the appearance of finished BMRC bushings. It can be seen that the BMRC material has been tightly bonded to the steel pipe inner surface.

3.7 Conclusion

The BMRC bushings are used in the boom foot and boom cylinder of PC200-7, PC300-7, and PC400-7 hydraulic excavators of the GALEO series. Since introduction of the hydraulic excavators to the market, some of the BMRC bushings have been used for about two years and a half. We have not received a single report that a squeak was caused by some of the BMRC bushings.

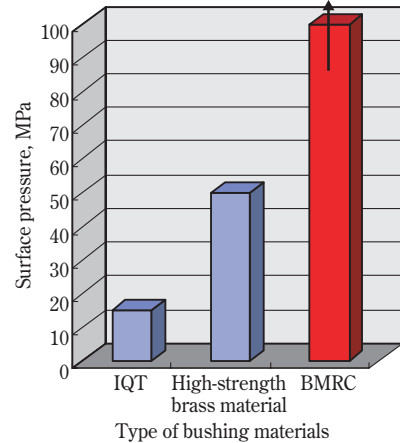

Fig. 3 Comparison of resistance to seizure

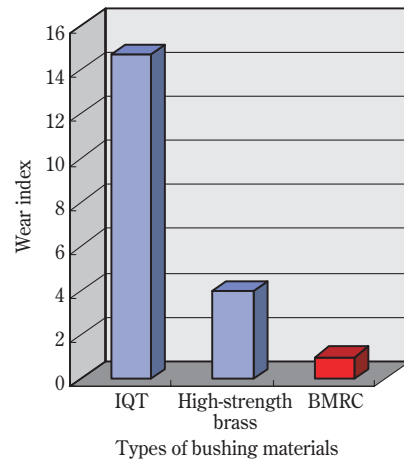

Fig. 4 Comparison of wear resistance



Photo 3 Appearance of BMRC bushings

Scheme of BMRC manufacturing process

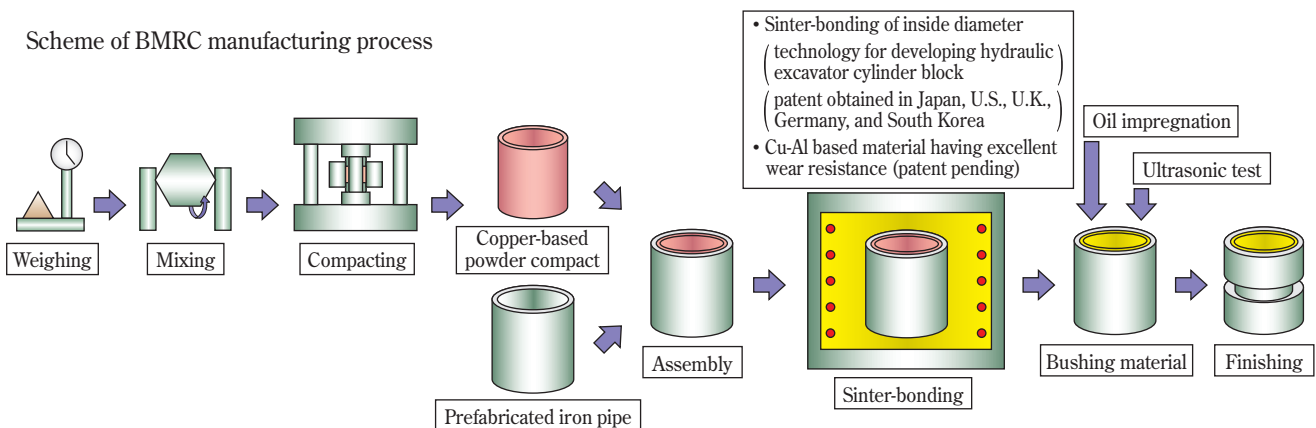

Fig. 5 BMRC manufacturing process

4. Development of OMRF material

4.1 OMRF material

Photo 4 shows a microstructure of the OMRF material.

From the network of copper in an iron-based matrix, it can readily be seen that the material has a high-strength sintered structure of Fe-Cu-C base.

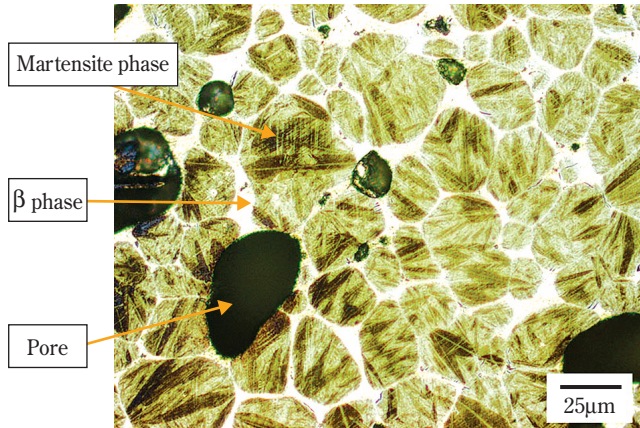

Photo 4 Microstructure of OMRF material

In the OMRF material, a very hard martensitic ferroalloy phase having regular transformation characteristic and a Cu-Al based alloy phase (β phase) form a network.

It is the OMRF material that has a very strong structure as the base and features excellent sliding characteristic. Like the BMRC material described above, the OMRF material was developed on the following concepts.

- ① Improve the sliding characteristic by introducing martensite which has regular transformation characteristic.
- ② Develop a material which offers a copper-based bonding excellent in strength and hardness.

As in the case of the BMRC material, the OMRF material can be sinter-bonded to the inner surface of a steel pile. However, since the OMRF material itself is very hard and strong, it can be applied even to a structure without back plate. Besides, it can be manufactured at low cost.

The appearance of OMRF bushings is shown in Photo 5.



Photo 5 Appearance of OMRF bushings

4.2 Characteristics of OMRF material

The basic composition of the OMRF material is shown in Table 3, and the mechanical properties of the material are shown in Table 4.

It can be seen that the OMRF material is superior in hardness and strength to the conventional sintered material (Fe-Cu-C base).

Table 3 Basic composition of OMRF material

Composition	Fe	Cu	Al	Special additives
Content	Remainder	20 - 25	5 - 10	5 - 7

Table 4 Mechanical properties of OMRF material

Item	OMRF material	Fe-Cu-C based sintered material
Tensile strength	300 - 350 MPa	150 MPa
Hardness	HRB; 70 - 95	HRB; 30 - 40
Oil content	15% - 20%	18% or more

4.3 Sliding characteristic of OMRF material

Fig. 6 shows the results of a bench test on the OMRF material, IQT material, and Fe-Cu-C-based sintered material. The test method used was the same as used for the BMRC material. Although the OMRF material is slightly inferior in seizure resistance to the BMRC material, it has better seizure resistance than the IQT and conventional materials.

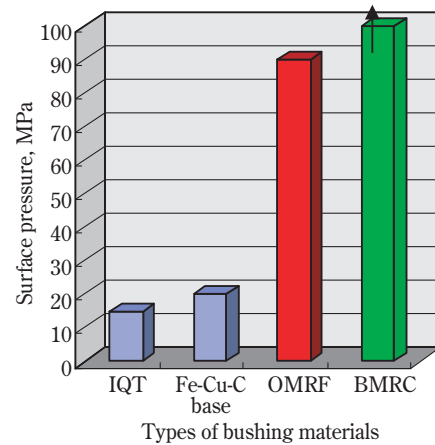

Fig. 6 Sliding characteristic of OMRF material

5. Conclusion

Improving the maintainability of hydraulic excavators has become a means of enhancing their functions. As a result, there is growing demand for a longer greasing interval of the work equipment bushings of hydraulic excavators. With the aim of meeting the demand, we carried out research focusing on new materials for oil-impregnated, self-lubricating bearings. On the basis of the research results, we could develop new materials for work equipment bushings which permit prolonging the greasing interval to 500 hours.

Namely, we came up with a copper-based material (BMRC) for parts which slide at a low speed and which require especially good resistance to seizure and an iron-based material (OMRF) for parts which require especially good wear resistance. These two types of materials are employed in all the suitable parts of PC400-7 hydraulic excavators according to their sliding conditions.

Introduction of the writers



Yoshikiyo Tanaka

Entered Komatsu in 1978. Currently working in Manufacturing Engineering Development Center, Production Division, Komatsu.



Masanori Ueyama

Entered Komatsu in 2002. Currently working in Manufacturing Engineering Development Center, Production Division, Komatsu.



Takemori Takayama

Entered Komatsu in 1981. Currently working in Manufacturing Engineering Development Center, Production Division, Komatsu.

[A few words from the writers]

The ongoing 'maintenance-free' movement is a good example which reflects the current of the times that demands freeing human beings from troublesome maintenance work. In view of this fact, we would like to continue refining the existing technology in that direction.