

Introduction of Micro Excavator PC09-1 in GALEO Series

Mikio Nojiri

Yoshiyuki Takano

For the first time in 10 years we completely changed the micro excavator PC03-2 which we had put on the market in 1993, and we put the PC09-1 on the market as the GALEO Series to meet the needs of the new age. We introduce this new machine PC09-1 below.

Key words: *Micro Shovel, Mini Hydraulic Excavator, Narrow Gauge, Steel Pressed Hood, Casting Revolving Frame*

1. Introduction

Micro excavators (smaller than 1 tonne) are used as excavators for pipe laying work for water supply and sewage systems in housing areas and they are helpful in hard work. They have 15% of the market share of mini hydraulic excavators (6 tonnes or smaller).

In recent years, since the needs for the micro excavators are also increasing in the North America and Europe, the exports of those excavators to those areas are increasing steadily.

The PC03-2 has been highly evaluated by the customers in the trades of pipe laying, building foundation construction, landscape gardening, etc. since it was put on the market in 1993. As Komatsu and other manufacturers have introduced the mini hydraulic excavators of 1-tonne class having small tail swing radius (MR type) into the market, however, the product power of the PC03-2 has decreased.

This time, we developed a new machine which was specially designed to be used as a micro excavator, considering the needs of the new age and sale to the overseas countries.

We introduce this new machine below. **(Photo 1)**



Photo 1 Appearance of PC09-1

2. Development concept

We started the development of the new machine to be specially used as a micro excavator under the concept that “the places where the machine can pass are the jobsites”.

(1) Special machine for narrow jobsites (Basic structure)
 Recently, in the mini hydraulic excavator market, machines of small tail swing radius type (hereinafter, referred to as MR type) have become the major products since the operators can swing them without paying attention to the rear.

When we developed the PC09-1, we discussed many times which type we should take, MR type or the conventional type, the rear of which projected when it swung (hereinafter, referred to as R type). Finally, we judged that the PC09-1 did not need to be MR type from its working condition.

- ① In narrow jobsites, the machine swings only 10 – 20° for dumping.
- ② Since the machine is small, the operator can check the rear easily.

Then, we verified our judgment by a customer survey. (Fig. 1)

- (2) Pursuit of basic functions and agreement with customer needs

We decided the following selling features of the PC09-1 before starting the development. (Fig. 2)

1. Outstanding operability in narrow jobsite

- Operable in jobsite for one-class smaller machine (Machine width: 800 mm → 700 mm)
- Stability secured during work
- Applicability of dumping by swinging upper structure in narrow jobsite (Slim rear shape)

2. High basic performance

- High stability
- Wide working range
- Strong digging force
- Tough travel performance

3. Functions gentle to operator

- Choice of travel speed (2 travel speeds)
- 2 travel levers easy to operate
- Swing pedal easy to operate
- Wide space for operator's feet
- Less vibrating and soft ride
- Operator's seat formed in 1 unit



4. Easy inspection, maintenance, and repair

- Engine hood which opens fully
- Greasing interval of 500 h for work equipment (excluding bucket parts)
- Large-sized fuel filler
- Grease-adjusted track
- Automatic air bleeding system for fuel circuit
- Operation pattern easy to change (ISO ↔ Komatsu)
- Exterior parts made of metal sheet

5. High reliability

- Built-in hydraulic hoses of work equipment
- Employment of flat face-to-face O-ring seals for hydraulic line
- Revolving frame and side deck made of cast iron in 1 unit
- Improved cooling performance

6. Pursuit of safety and consideration to the environment

- Employment of safety lock lever interlocked with travel lock
- Improved recyclability
- Ultra low noise

7. High versatility

- Arm having breaker in it
- Bucket coupler
- Variable gauge

Fig. 2 Selling features of PC09

Strength of request for small tail swing radius

PC01 R type	79%	21%	
PC02 R type	8%	65%	27%
PC03 R type	15%	63%	22%

- Small tail swing radius is important
 - There is no possibility of hitting machine against walls, buildings, etc.
 - Dumping by swinging upper structure is more required than dumping by swinging boom.
- Small tail swing radius is good, but other features are more necessary
 - Small tail swing radius is good, but stability is more important.
 - “Stability, digging force, working range, etc. are equal to those of current model” is requisite.
 - Small tail swing radius of current model is satisfactory. (There seems to be no merits.)
- Small tail swing radius is not necessary
 - Since jobsites are so narrow that even a small machine cannot swing, small tail swing radius is not necessary.
 - Current model is satisfactory.

Fig. 1 Strength of request for small tail swing radius

- (3) Design for operation in overseas countries

In the past, machines for overseas countries were manufactured by modifying the machines for Japanese market to meet the standards and regulations of each country. Accordingly, man-hours for examination and modification were necessary.

On the other hand, the items required by each destination were put to the PC09 from the first stage of the design. (See Table 1)

Table 1 Design for operation in overseas countries

	Japan	Europe	North America
Travel lock	◎	◎	◎
TOPS	—	◎Option	◎
Seat belt	—	○	○
Travel alarm	—	—	○
Conformance to 45°C	◎	◎	◎
Variable gauge	◎Option	◎	◎
Paint (Yellow)	◎	◎	◎
Optional power supply	—	○	—
Mark	○	○	○
Hose guard	—	◎	◎
Seat sliding mechanism	—	◎	◎
Anti-explosion battery	—	—	○

An item marked with ◎ is common.

(4) 3D development

Komatsu Zenoah Co. applied full 3D development for the first time. The following items were the concept of the 3D development.

- ① Simultaneous development by all the departments
- ② Disclosure of information in an early period by utilizing intralink system
- ③ Reduction of the measures against high stress by the FEM analysis of the main component parts (revolving frame, track frame) before issue of the trial manufacture drawing
- ④ Passing the TOPS test in one try by performing the elastic and plastic analysis of the 2-leg TOPS employed for the first time

The good points in the result are as follows.

- ① We invited the cooperating companies to our company and held a plan drawing examination meeting by 3D to improve the productivity.
- ② Since the concerned departments held a pre-examination meeting before the plan drawing examination meeting, the quality of the latter was improved.
- ③ The designers performed the FEM analysis for themselves and had responsibility until the development was finished. The analysis result of the stresses on the revolving frame and track frame passed the test in one try.
- ④ We passed the TOPS test in one try. The true deformation almost agreed with the analysis result. We confirmed the horizontal application to the development in future. (Fig. 3, Fig. 4)

The bad points in the result are as follows.

Since many map compositions were used, the layers of the model became complicated and modification became difficult.

All departments are examining the merits and demerits obtained from the 3D development of the PC09 and making a system for the next development.

We believe that we almost attained the role and purpose of the development of the pilot 3D.



Fig. 3 TOPS of PC09

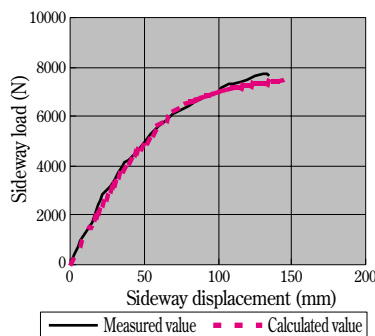

Fig. 4 Load-displacement curves of TOPS of PC09

3. Main features

(1) Facility in entering narrow jobsite

The width of the PC09-1 is set to 700 mm so that it can enter narrow jobsites similarly to the PC02-1 which is one-class smaller. (Table 2)

Table 2 Machine body width table

	PC09-1	PC03-2	PC02-1
Machine body width (mm)	700	800	690

(2) Facility in dumping in narrow jobsite

To meet the customer's request that they should be able to "dump by swinging the upper structure rather than by swinging the boom", the rear part of the machine body is reduced in size. As a result, the operator can dump by swinging the upper structure slightly without swinging the boom even in a jobsite where the space for working is limited. (Fig. 5, Fig. 6)

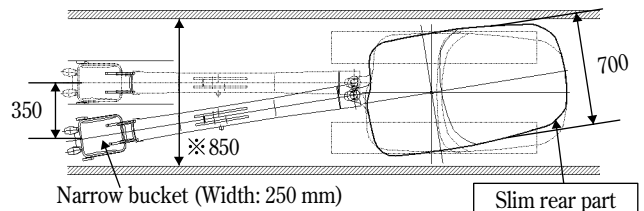

Narrow bucket (Width: 250 mm) Slim rear part

※The distance between the inside wall surfaces is set to 850 mm for comparison with the PC03-2.

Fig. 5 Dumping of PC09-1 by swinging upper structure

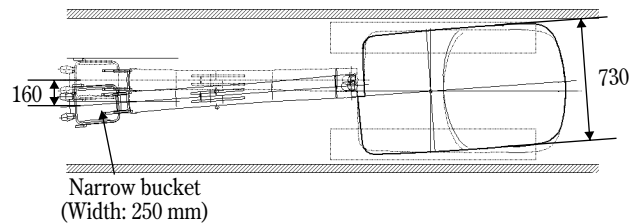

Narrow bucket (Width: 250 mm)

Fig. 6 Dumping of PC03-2 by swinging upper structure

(3) High stability

The PC09-1 employs the track roller of outside flange type to increase the effective width for sideway stability. As a result, the stability of PC09-1 which has the body width of only 700 mm is similar to that of the PC03-2 which has the body width of 800 mm. (Fig. 7, Table 3)

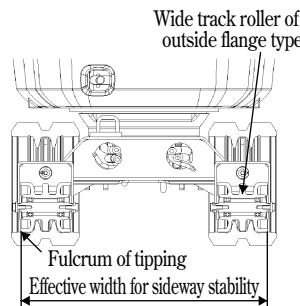

Fig. 7 Effective width for sideway stability of PC09

Table 3 Stability table

	PC09-1	PC03-2	PC02-1
Machine width (mm)	700	800	690
Effective width for sideway stability (mm)	653	640	540
Shape of track roller	Wide and outside flange type	Inside flange type	Inside flange type
Forward stability	28%	28%	28%
Sideway stability	26%	26%	28%

(4) Wide working range and strong digging force

The working range and digging force are based on the PC03-2 which has been highly evaluated. This feature and facility in entering narrow jobsite can reduce the hard work.

(5) 2 travel speeds

The travel speed of the PC09-1 can be set to the 1st of 1.5 km/h or 2nd of 3.0 km/h. Accordingly, the PC09-1 can move faster than the PC03-2 that has fixed its speed to 2.1 km/h.

(6) 2 travel levers and swing pedal easy to operate

Similarly to the upper models, the PC09-1 has 2 travel levers and both-ended swing pedal on the right side for higher controllability. (Photo 2, Photo 3, Photo 4)



Similarly to upper models, right and left independent travel levers are installed so that operator can clearly distinguish operations of both tracks.

Photo 2
Travel levers of PC09-1



Operator moves single lever forward and back and twist it to control travel.

Photo 3
Travel lever of PC03-2

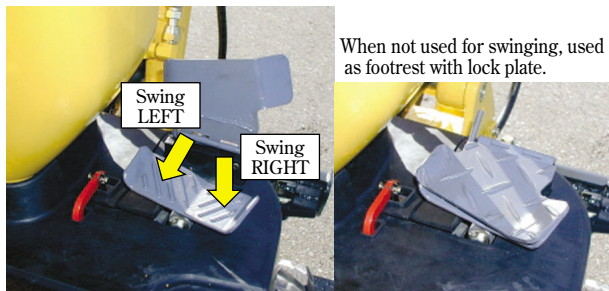

Similarly to upper models, both-ended swing pedal is installed on the right side.

Photo 4 Swing pedal of PC09-1

(7) Less vibrating and soft ride

The track roller of outside flange type less sinks than that of inside flange type during travel. In addition, the special rubber track which has lugs between the cores is employed to attain a less vibrating and soft ride. (Fig. 8)

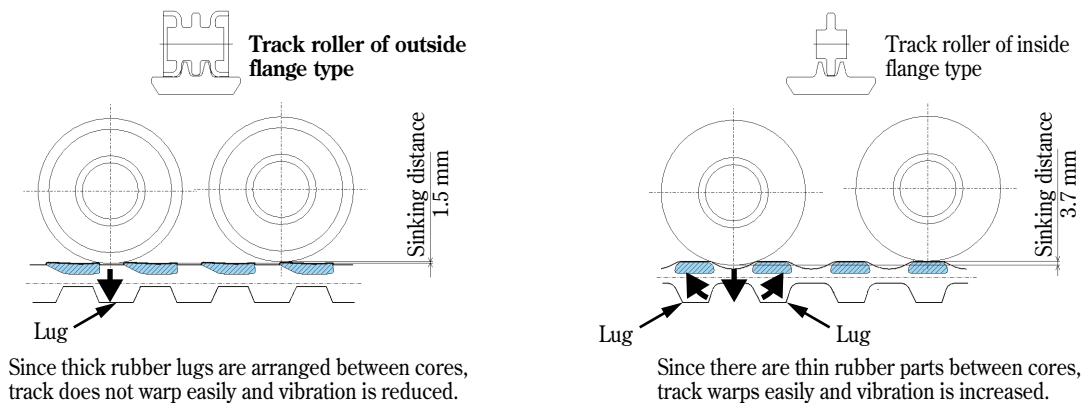

Fig. 8 Comparison of track rollers and rubber shoes

(8) Easy inspection and maintenance

Since the fully openable hood is employed, inspection and maintenance are facilitated greatly. (Photo 5, Photo 6)

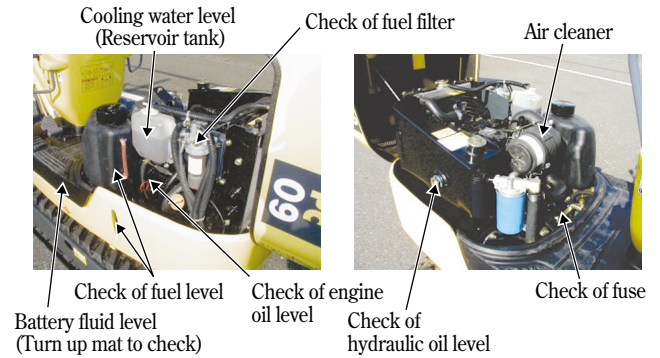

Photo 5 Maintainability of PC09-1



Since only upper hood cover can be opened on the PC03, some items are under cover and cannot be checked easily.

Photo 6 Maintainability of PC03-3

(9) Large-sized fuel filler

The large-sized fuel filler is employed so that fuel will be supplied easily and will not spill over. (Fig. 9)

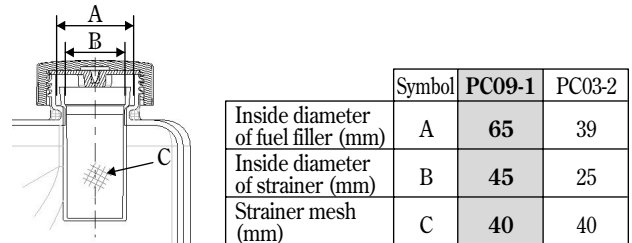

Fig. 9 Comparison of fuel filler

(10) Exterior parts made of metal sheet and side deck made of cast iron

The 1-piece engine hood made of metal sheet by pressing is employed for the ease of repair.

The side deck and revolving frame made of cast iron in 1 unit have high resistance to impacts and high durability. **(Photo 7)**

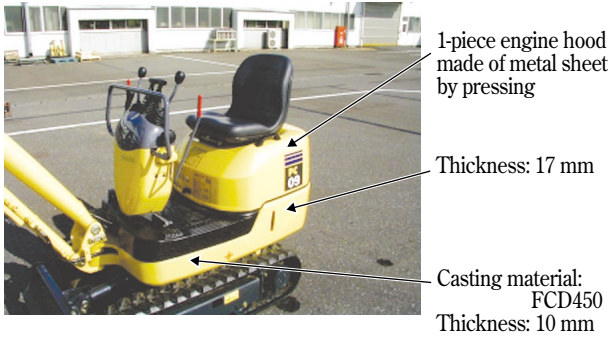

Photo 7 Hood and side deck of PC09-1

(11) Ultra low noise

The noise is lowered by employing the hood made of metal sheet and special silencer. As a result, even the “tone “ which cannot be expressed by a value is improved. Since the noise at operator’s ear is also lowered, the PC09-1 is gentle to the operator and the environment. **(Table 4)**

Table 4 Comparison of noise

		PC09-1	PC03-2
Dynamic noise around machine	dB(A)	89.6	90.7
Noise at operator’s ear (When relieved)	dB(A)	75.3	76.9

The standard for the ultra low noise machine is that the dynamic noise around the machine is below 93 dB(A).

(12) Improved cooling performance (Conformance to 45°C)

The aluminum-made radiator having a louver is employed to improve the cooling performance. The high, long, and narrow hydraulic tank is employed to utilize heat radiation by the cooling air. **(Fig. 10)**

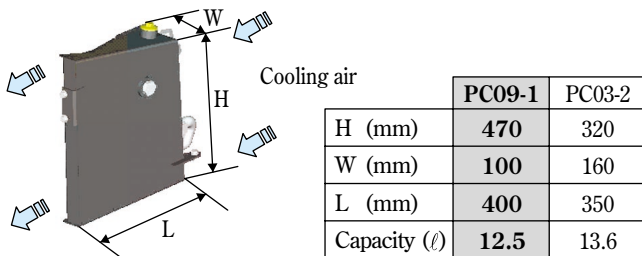

Fig. 10 Outside dimensions of hydraulic tank

(13) Safety lock lever interlocked with travel lock

The safety lock lever interlocked with travel lock is employed for higher safety. **(Photo 8)**

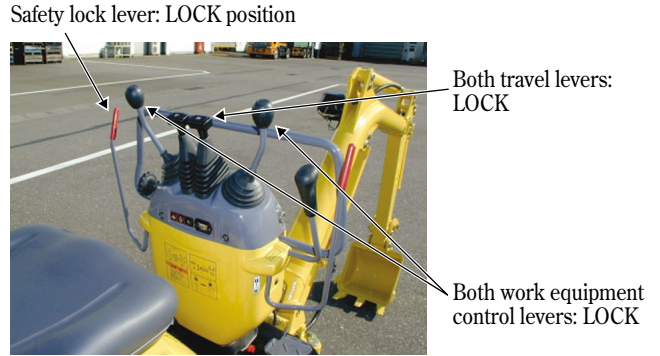

Photo 8 Safety lock lever

(14) Improved recyclability

Many plastic parts are employed for the exterior parts of the PC03-2. They are reduced for the PC09-1 as many as possible, however, from the point of view of recycling.

Plastic exterior parts of the PC03-2 → Hood made of metal sheet, side deck and revolving frame unit

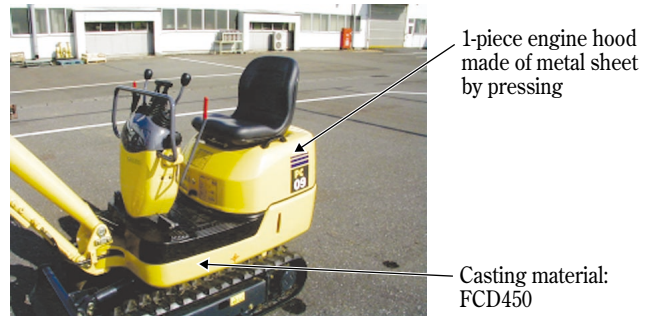

Photo 9 Hood and side deck of PC09-1

(15) Reduction of environmental load material

The copper-made radiator is replaced with the aluminum-made one and no lead is used to reduce the environmental load material which has bad effects on human bodies. **(Table 5)**

Table 5 Comparison of quantity of lead used

	PC09-1	PC03-2
Quantity of lead used	0g	160g
Material of radiator core	Aluminum	Copper

Lead is used to joint the cooling fins and tubes of the copper-made radiator.

4. Result of customer evaluation

We performed a post-launch field survey for customer evaluation in November 2002, 9 months after we had put the PC09-1 on the market.

Outline of result (Fig. 11)

The general evaluation point by the customers was 4.2 out of 5.0, which was good. Eighty percent of the customers do not mind the projection of the rear part.

- Facility in entering narrow jobsite is evaluated frankly.
- Noise (around machine and at operator’s ear) is evaluated high.
- Large-sized oil filler cap is evaluated high.

5. Conclusion

The PC09-1 has been selling steadily in both Japanese and overseas markets since it was put on the market and we are almost satisfied with the result. We intend to stabilize the quality of this machine further.

Introduction of the writers



Mikio Nojiri

Entered Komatsu Zenoah Co. in 1981. Currently working in Construction Machinery Development Dept., Development Div., Komatsu Zenoah Co.



Yoshiyuki Takano

Entered Komatsu Zenoah Co. in 1994. Currently working in Construction Machinery Development Dept., Development Div., Komatsu Zenoah Co.

[A few words from the writers]

Komatsu Zenoah Co. applied the 3D design to the model change of the PC09-1 of this time for the first time. Since this was the first experience to the designers, concerned departments, cooperating companies, and us, we made necessary rules and took 20 months before we started the full-scale production by feel. When we look back over those days, the most important thing seems to be that each person made and kept the determination to “complete the 3D”.

We realized that gathering individuals can produce large power and “continuation is a kind of power”. We will remember this as our spiritual nourishment in the future.

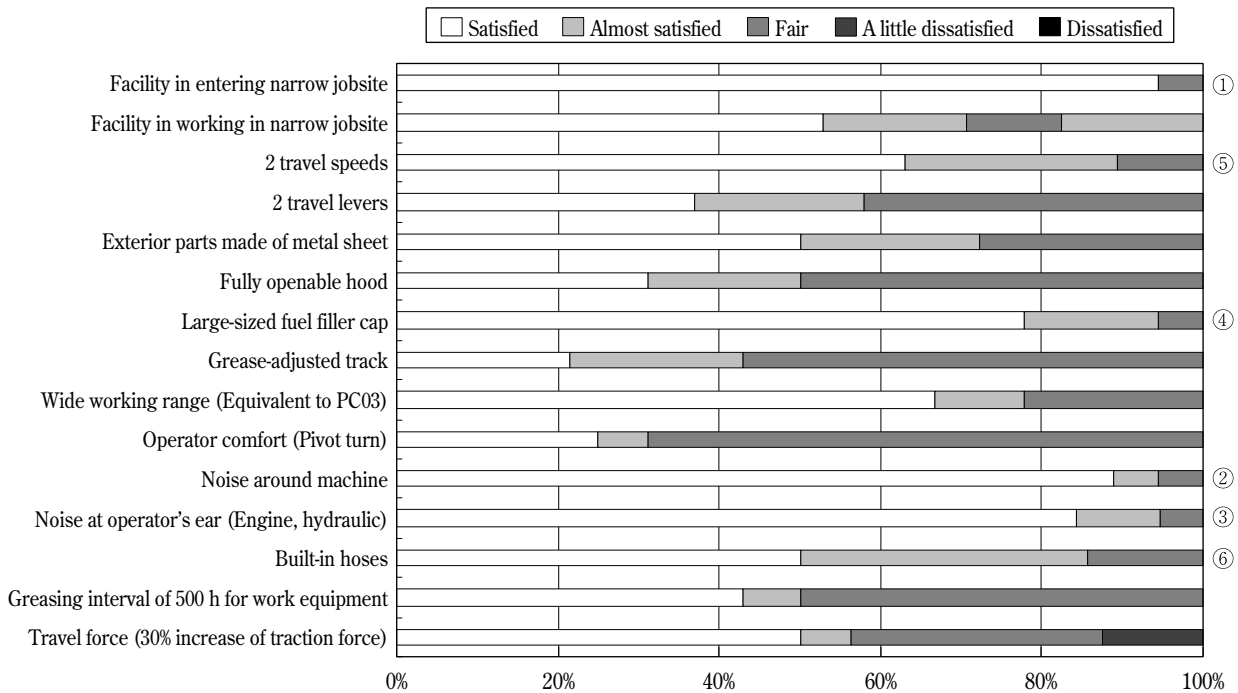

Fig. 11 Summary of customer evaluation